



**ZUCHELLI**  
**F O R N I**

# FORNI ROTATIVI

TOP ROTOR • ROTORFAN  
ROTARY OVENS  
HORNOS ROTATIVOS  
FOURS ROTATIFS





Maniglia porta con impugnatura in bachelite nera termo-refrattaria.



Door handle with black thermo-refractory Bakelite hilt.



Manilla de la puerta con empuñadura de baquelita negra termo refractaria.



Poignée porte en bakélite noire thermo-réfractaire.

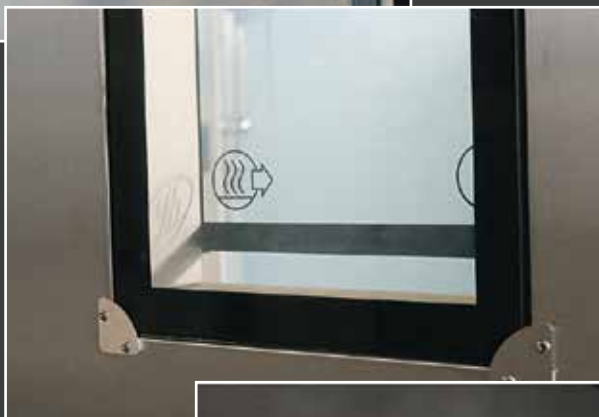

Doppio vetro per un maggior isolamento termico.



Double glazing for better thermal insulation.



Cristal doble para un mayor aislamiento térmico.



Double vitrage pour une meilleure isolation thermique.



Porta robusta e di notevole spessore.



Very thick and sturdy door.



Puerta resistente y de gran espesor.



Porte robuste et d'une épaisseur considérable.



Nei forni a convezione il calore viene trasmesso al prodotto in cottura attraverso un flusso d'aria calda fatta circolare forzatamente all'interno del forno. La rotazione del carrello all'interno del forno permette al flusso d'aria di raggiungere completamente il prodotto in cottura, garantendone in questo modo una cottura uniforme.



In convection ovens the heat is transferred to the product being baked by a flow of hot air, circulating inside the oven. The rotation of the rack inside the oven allows the air flow to be fully invested in baking the product, thus ensuring even baking.



En los hornos de convección el calor se transmite al producto en cocción a través un flujo de aire caliente que circula de manera forzada dentro del horno. La rotación del carro en del horno permite que el flujo de aire alcance completamente el producto en cocción, garantizando de esta manera su cocción uniforme.



Dans les fours à convection, la chaleur est transmise au produit en cours de cuisson à travers un flux d'air chaude à circulation forcée à l'intérieur du four. La rotation du chariot à l'intérieur du four permet au flux d'air de chauffer entièrement le produit en cours de cuisson, garantissant ainsi une cuisson homogène.

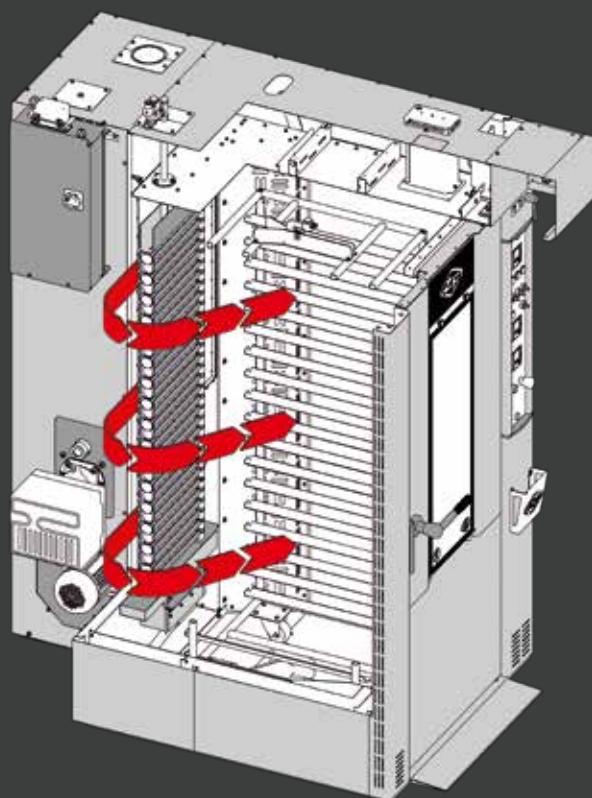

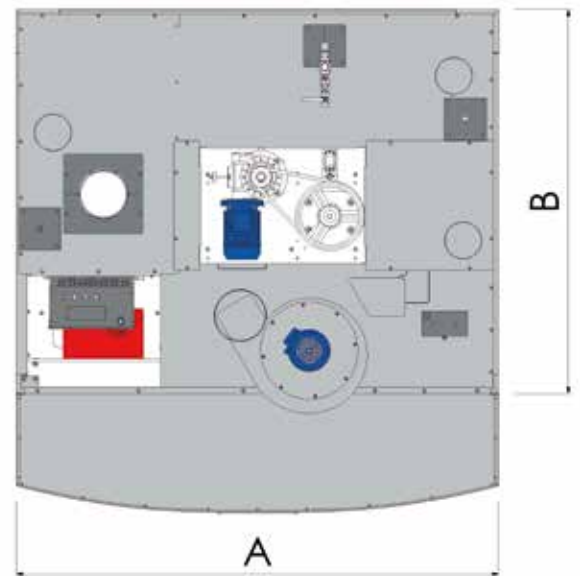
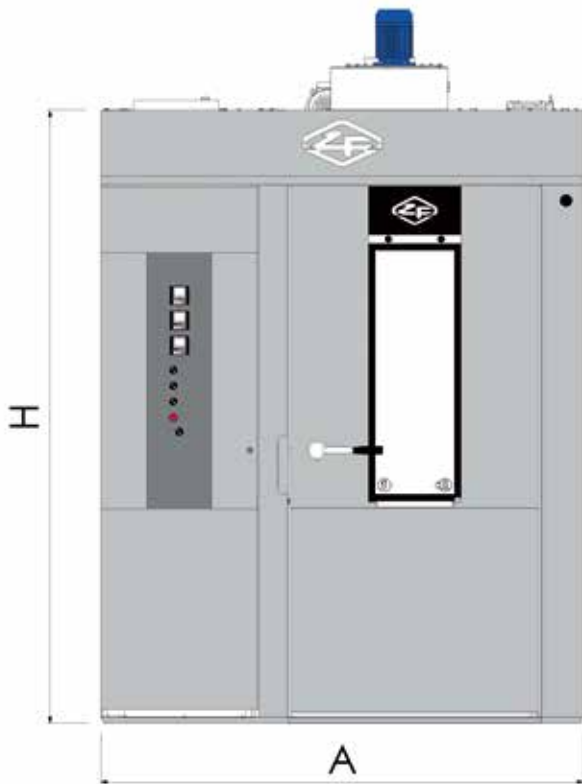

## TOP ROTOR

Modello Model Modelo Modèle	Dimensioni teglia Tray dimensions Dimensiones bandejas Dimensions plaques	Superf. Cottura Baking surface Superf. cocción Surface cuisson	Produtz. Oraria Hourly output Produc. por hora Prod. horaire	Dimensioni est. External dimensions Dimensiones exteriores Dimensions extérieures			Peso Weight Peso Poids	Teglie per carrello Trays for rack Bandejas por carro Plaques pour chariot	Potenza termica Thermal power Potencia termica Puissance thermique	Potenza elettrica Electric power Potencia electrica Puissance électrique	
				A	B	H				Bruc. Burner Quem. Brul.	Resist. Resist. Resist. Resist.
<b>TOP MINIROTOR</b>	40x60	3,6	50	140	111	202	650	15	29.000	1	23,5
<b>TOP MINIFALCON</b>	45x65 50x70	4,3 5,2	60 70	155	124	202	700	15	35.000	1	28
<b>TOP FALCON</b>	45x65 50x70	5,2 6,3	70 82	155	124	217	770	18	40.000	1	28
<b>TOP ROTOR 60x80</b>	60x80	8,6	120	183	145	233	1380	18	55.000	2	47
<b>TOP ROTOR 65x92</b>	65x92 80x80	10,7 11,5	135	200	162	233	1400	18	60.000	2	47
<b>TOP ROTOR 80x100</b>	80x100	14,4	195	234	178	233	1600	18	70.000	3,5	58
<b>TOP ROTOR 80x120</b>	80x120	17,2	235	257	200	233	2000	18	80.000	3,5	71
<b>TOP ROTOR 100x130</b>	100x130	23,4	310	280	217	233	2100	18	95.000	4	85

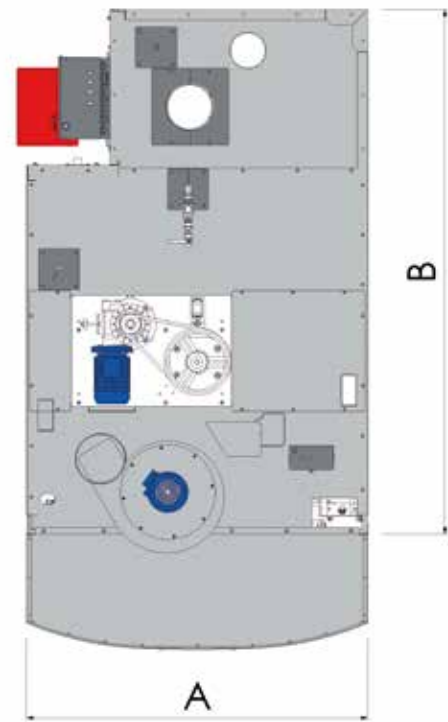
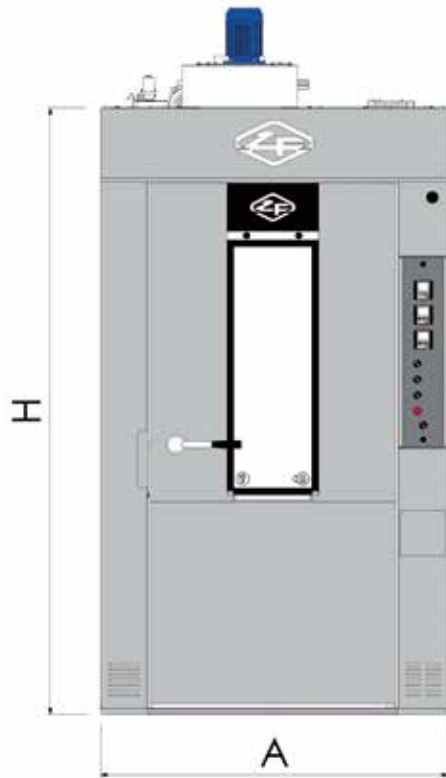

## ROTORFAN

Modello Model Modelo Modèle	Dimensioni teglia Tray dimensions Dimensiones bandejas Dimensions plaques	Superf. Cottura Baking surface Superf. cocción Surface cuisson	Produtz. Oraria Hourly output Produc. por hora Prod. horaire	Dimensioni est. External dimensions Dimensiones exteriores Dimensions extérieures			Peso Weight Peso Poids	Teglie per carrello Trays for rack Bandejas por carro Plaques pour chariot	Potenza termica Thermal power Potencia termica Puissance thermique	Potenza elettrica Electric power Potencia electrica Puissance électrique	
				A	B	H				Bruc. Burner Quem. Brul.	Resist. Resist. Resist. Resist.
<b>MINIROTORFAN 40x60</b>	40x60	3,6	50	100	150	202	650	15	29.000	1	23,5
<b>MINIROTORFAN 50x70</b>	45x65 50x70	4,3 5,2	60 70	112	168	202	800	15	35.000	1	28
<b>ROTORFAN 50x70</b>	45x65 50x70	5,2 6,3	70 82	112	168	217	850	18	40.000	1	28
<b>ROTORFAN 5 60x80</b>	60x80	7,2	100	133	205	203	1050	15	55.000	1,5	42
<b>ROTORFAN 60x80</b>	60x80	8,6	120	133	205	233	1100	18	55.000	2	47
<b>ROTORFAN 8</b>	65x92 80x80	10,7 11,5	135	147	218	233	1150	18	60.000	2	47
<b>ROTORFAN 4</b>	80x100	14,4	195	153	240	233	1400	18	70.000	3,5	58
<b>ROTORFAN 9</b>	80x120	17,2	235	178	261	233	1800	18	80.000	3,5	71



## MINIROTOR E

Modello Model Modelo Modèle	Superf. Cottura Baking surface Superf. cocción Surface cuisson	Produtz. Oraria Hourly output Produc. por hora Prod. horaire	Dimensioni est. External dimensions Dimensiones exteriores Dimensions extérieures			Peso Weight Peso Poids	Teglie per carrello Trays for rack Bandejas por carro Plaques pour chariot	Potenza termica Thermal power Potencia termica Puissance thermique	Potenza elettrica Electric power Potencia electrica Puissance électrique
			A	B	H				
	m <sup>2</sup>	kg	cm	cm	cm	kg	nr	kcal	kw
<b>MINIROTOR E 40x60</b>	3,6	50	98	119	202	550	15	-	23,5
<b>MINIROTOR E 50x70</b>	4,3 5,2	60 70	112	143	202	600	15	-	28

# CELLE DI LIEVITAZIONE

PROOFERS FOR ROTARY OVENS

CAMARAS DE FERMENTACION PARA HORNOS ROTATIVOS

CHAMBRES DE FERMENTATION POUR FOURS ROTATIFS

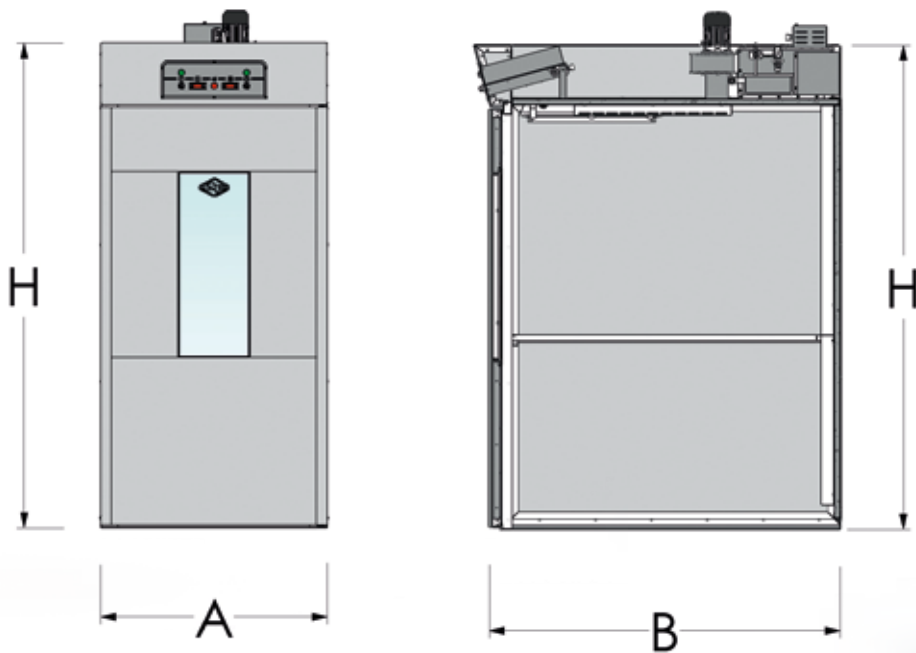

Modello Cella Proofer model Modelo cámara Modèle chambre	Carrelli Racks Carros Chariots	Porte Doors Puertas Portes	Dimensioni est. External dimensions Dimensiones exteriores Dimensions extérieures			Potenza elettrica Electric power Potencia eléctrica Puissance électrique
			A	B	H	
			cm	cm	cm	
<b>MINI 40x60</b>	2	1	100	122	200	3
	2	2	160	104	200	3
	4	2	202	132	200	3
<b>MINI 45x65/50x70</b>	2	1	100	132	200	3
	2	2	160	104	200	3
	4	2	202	132	200	3
<b>ROTORFAN - FALCON 45x65/50x70</b>	2	1	100	132	215	3
	2	2	160	104	215	3
	4	2	202	132	215	3
<b>ROTORFAN 5 60x80</b>	2	1	100	194	200	4
	2	2	202	107	200	4
	4	2	202	194	200	6
<b>ROTOR 60x80</b>	2	1	108	167	230	4
	2	2	218	107	230	4
	4	2	218	167	230	6
<b>ROTOR 65x92/80x100</b>	2	1	108	230	230	4
	2	2	218	126	230	4
	4	2	218	230	230	6
<b>ROTOR 80x120</b>	2	1	108	270	230	5
	2	2	218	146	230	5
	4	2	218	270	230	8



- Struttura portante in acciaio inox e rivestimento esterno in doppia parete metallica con intercapedine isolante. Con o senza basamento.
- Il calore e l'umidità sono erogati indipendentemente con un apposito gruppo di riscaldamento dotato di ventilatore e resistenze per garantire un'uniformità di lievitazione su tutti i prodotti.



- Supporting structure made of stainless steel, double external metal covering with isolated hollow space. With or without floor.
- Heat and humidity are provided independently through a special heating group equipped with ventilator and heating elements in order to grant an even leavening of all products



- Estructura portante de acero inoxidable, revestimiento exterior con doble pared metálica con espacio intermedio aislante. Con o sin suelo.
- El calor y la humedad vienen distribuidos por un grupo de calefacción, dotado de ventilador y resistencias, para garantizar uniformidad de fermentación en todos los productos.



- Structure en acier inox, revêtement extérieur avec double paroi métallique avec un espace d'isolation. Avec ou sans sol.
- La chaleur et l'humidité sont distribuées de façon indépendante par un groupe de chauffage équipé des ventilateurs et résistances afin de garantir une fermentation uniforme à tous les produits.





Los hornos rotativos, gracias a su facilidad de conducción, son aptos para ser instalados en cualquier laboratorio de panadería y pastelería. Cambiador de calor a tres giros que aprovecha al máximo el calor producido en la combustión, permitiendo una cocción más regular con consumo menor. Cámara de cocción y fachada de acero inox, paneles exteriores de chapa galvanizada pintada. Funcionamiento eléctrico o con quemador a gas o gasóleo. Cuadro de mandos electromecánico, LCD o Touch. Vaporizador de nueva concepción que garantiza el suministro abundante de humedad en todos los puntos del carro. Tres sistemas de enganche del carro: plataforma giratoria, enganche superior o levantamiento automático.

**Versiones:**

TOP ROTOR: cámara de combustión y quemador en la parte anterior a la izquierda.  
 ROTORFAN: cámara de combustión y quemador en la parte a trasera a la izquierda.

**Opciones:**

Paneles exteriores de acero inox.  
 Modelo Rotorfan se puede suministrar en versión "invertida" (quemador a la derecha).



Les fours rotatifs, avec leur facilité d'utilisation, peuvent être installés dans n'importe quelle boulangerie ou pâtisserie. L'échangeur assure une exploitation optimale de la chaleur produite par la combustion : une cuisson plus régulière avec une économie d'énergie. Chambre de cuisson et façade en acier inox, panneaux extérieurs en tôle galvanisée peinte. Fonctionnement électrique ou avec brûleur gaz ou mazout. Tableau commande électromécanique, LCD ou Touch. Appareil à vapeur de nouvelle conception qui permet une humidité importante dans tous les points du chariot. Trois systèmes d'accrochage du chariot: plate-forme tournante, accrochage supérieur ou soulèvement automatique.

**Versions:**

TOP ROTOR: chambre de combustion et brûleur à l'avant à gauche.  
 ROTORFAN: chambre de combustion et brûleur à l'arrière à gauche.

**Options:**

Panneaux extérieurs en acier inoxydable.  
 Model Rotorfan en version "à l'envers" (brûleur à droite).



I forni rotativi grazie alla loro facilità di conduzione sono adatti ad essere installati in qualsiasi laboratorio di panetteria e pasticceria. Scambiatore di calore a tre giri di fumi che, sfruttando al meglio il calore prodotto dalla combustione, permette una cottura più regolare con un minor consumo. Camera di cottura e facciata in acciaio inox, pannellatura esterna in lamiera preverniciata. Funzionamento elettrico o con bruciatore a gas o gasolio. Pannello comandi elettromeccanico, LCD o Touch. Umidificatore di nuova concezione che garantisce un'abbondante erogazione di vapore in ogni punto del carrello. Tre sistemi di aggancio del carrello: piattaforma girevole, aggancio superiore o sollevamento automatico.

**Versioni:**

TOP ROTOR - con camera di combustione e bruciatore sul lato sinistro anteriore.  
 ROTORFAN - con camera di combustione e bruciatore nella parte posteriore sinistra.

**Options:**

Pannellatura esterna in acciaio inox.  
 Modelli ROTORFAN versione "rovescia" (con bruciatore a destra).



Due to the easiness of operation the Rotor ovens are ideal for installation in any bread or pastry shop. The heat exchanger with three turns exploits the heat produced in the combustion better, ensuring more uniform baking with lower consumption. Baking chamber and oven front in stainless steel, external panelling in painted sheet steel. Electric function or with gas/gas oil burner. Control panel: electromechanical, LCD or Touch. New conception of steam generator which grants abundant steam supply all over the baking rack. Three rack hooking systems: rotating platform, top hook or automatic lifting device.

**Versions:**

TOP ROTOR: combustion chamber and burner on the left front side.  
 ROTORFAN: with combustion chamber and burner on the left rear side.

**Options:**

External panelling in stainless steel.  
 Rotorfan oven in the "counter manufactured" version (burner on the right side).





**ZUCHELLI  
FORNI**

Zucchelli Forni S.p.a.  
37060 - Trevenzuolo (Vr) - Italy  
Zona Artigiana S. Pierino  
Tel. 045 6680068 r.a. - Fax 045 7350285

[www.zucchelliforni.it](http://www.zucchelliforni.it)  
e-mail: [info@zucchelliforni.it](mailto:info@zucchelliforni.it)