

## MINISTAR

Modello <i>Model</i> <i>Modèle</i> <i>Modelo</i>	Sup. cottura <i>Baking surf.</i> <i>Surf. cuisson</i> <i>Sup. cocción</i>	Dim. camere <i>Decks dim.</i> <i>Dim. Chambres</i> <i>Dim. cámaras</i>		Dim. esterne <i>External dim.</i> <i>Dim. extérieures</i> <i>Dim. externas</i>		Peso <i>Weight</i> <i>Poids</i> <i>Peso</i>	Potenzialità termica <i>Thermal power</i> <i>Puissance thermique</i> <i>Potencia térmica</i>			Ass. elettrico <i>Elec. absorption</i> <i>Puissance élec.</i> <i>Potencia eléc.</i>
		A cm	B cm	C cm	D cm		Kcal/h	Kw	BTU/h	
<b>4 CAMERE - 4 DECKS - 4 ETAGES - 4 CAMARAS</b>										
<b>MSR-40810</b>	3.44	82	105	130	198	1280	28.000	32	112.000	1
<b>MSR-40812</b>	4.10		125		218	1550	30.000	35	120.000	
<b>MSR-40814</b>	4.76		145		238	1600	32.000	37	128.000	
<b>MSR-40816</b>	5.41		165		258	1750	36.000	42	144.000	
<b>MSR-40818</b>	6.07	82	185	130	278	1850	38.000	44	152.000	1
<b>MSR-40820</b>	6.72		205		298	1950	44.000	51	176.000	
<b>MSR-41010</b>	4.28		102		105	150	198	1550	32.000	
<b>MSR-41012</b>	5.10	125		218	1700		34.000	39	136.000	
<b>MSR-41014</b>	5.92	145		238	1800		36.000	42	144.000	
<b>MSR-41016</b>	6.73	165		258	2000		38.000	44	152.000	

<b>5 CAMERE - 5 DECKS - 5 ETAGES - 5 CAMARAS</b>										
<b>MSR-50810</b>	4.31	82	105	130	198	1600	30.000	35	120.000	1
<b>MSR-50812</b>	5.13		125		218	1750	32.000	37	128.000	
<b>MSR-50814</b>	5.95		145		238	1900	34.000	39	136.000	
<b>MSR-50816</b>	6.77		165		258	2050	36.000	42	144.000	
<b>MSR-50818</b>	7.59	82	185	130	278	2200	38.000	44	152.000	1
<b>MSR-50820</b>	8.41		205		298	2350	44.000	51	176.000	
<b>MSR-51010</b>	5.36		102		105	150	198	1750	34.000	
<b>MSR-51012</b>	6.37	125		218	1900		36.000	42	144.000	
<b>MSR-51014</b>	7.40	145		238	2050		38.000	44	152.000	
<b>MSR-51016</b>	8.42	165		258	2200		40.000	46	160.000	

<b>6 CAMERE - 6 DECKS - 6 ETAGES - 6 CAMARAS</b>										
<b>MSR-60810</b>	5.15	82	105	130	198	1900	33.000	38	132.000	1
<b>MSR-60812</b>	6.15		125		218	2100	35.000	41	140.000	
<b>MSR-60814</b>	7.13		145		238	2300	37.000	43	148.000	
<b>MSR-60816</b>	8.12		165		258	2450	40.000	46	160.000	
<b>MSR-60818</b>	9.10		185		278	2650	42.000	49	168.000	

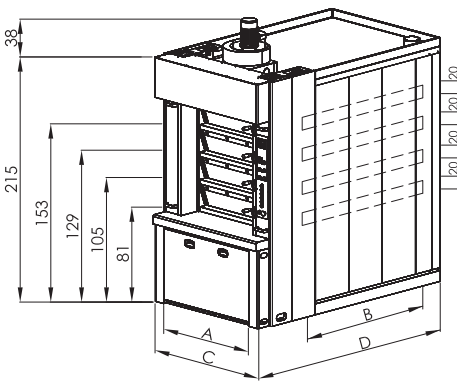

MSR 4

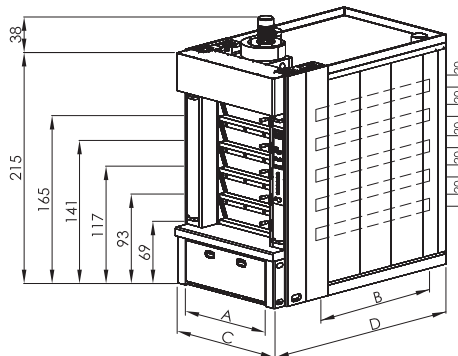

MSR 5

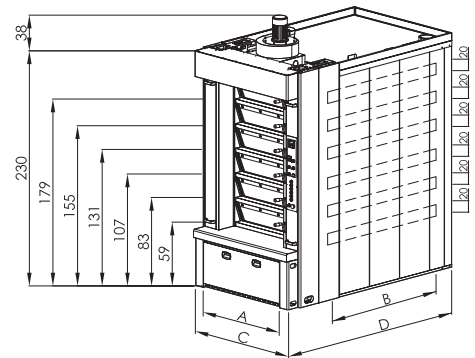

MSR 6

## MINISTAR STONE - PELLET

Modello <i>Model</i> <i>Modèle</i> <i>Modelo</i>	Sup. cottura <i>Baking surface</i> <i>Surf. cuisson</i> <i>Sup. cocción</i>	Dim. camere <i>Decks dim.</i> <i>Dim. Chambres</i> <i>Dim. cámaras</i>		Dim. esterne <i>External dim.</i> <i>Dim. extérieures</i> <i>Dim. externas</i>		Peso <i>Weight</i> <i>Poids</i> <i>Peso</i>	Potenzialità termica <i>Thermal power</i> <i>Puissance thermique</i> <i>Potencia térmica</i>			Ass. elettrico <i>Elec. absorption</i> <i>Puissance élec.</i> <i>Potencia eléc.</i>
		A cm	B cm	C cm	D cm		Kcal/h	Kw	BTU/h	
<b>4 CAMERE - 4 DECKS - 4 ETAGES - 4 CAMARAS</b>										
MSP-40810	3.44	82	105	130	203	1280	28.000	32	112.000	1
MSP-40812	4.10		125		223	1550	30.000	35	120.000	
MSP-40814	4.76		145		243	1600	32.000	37	128.000	
MSP-40816	5.41	82	165	130	263	1750	36.000	42	144.000	1
MSP-40818	6.07		185		283	1850	38.000	44	152.000	
MSP-40820	6.72		205		303	1950	44.000	51	176.000	
MSP-41010	4.28	102	105	150	203	1550	32.000	37	128.000	1
MSP-41012	5.10		125		223	1700	34.000	39	136.000	
MSP-41014	5.92		145		243	1800	36.000	42	144.000	
MSP-41016	6.73		165		263	2000	38.000	44	152.000	

### 5 CAMERE - 5 DECKS - 5 ETAGES - 5 CAMARAS

MSP-50810	4.31	82	105	130	203	1600	30.000	35	120.000	1
MSP-50812	5.13		125		223	1750	32.000	37	128.000	
MSP-50814	5.95		145		243	1900	34.000	39	136.000	
MSP-50816	6.77	82	165	130	263	2050	36.000	42	144.000	1
MSP-50818	7.59		185		283	2200	38.000	44	152.000	
MSP-50820	8.41		205		303	2350	44.000	51	176.000	
MSP-51010	5.36	102	105	150	203	1750	34.000	39	136.000	1
MSP-51012	6.37		125		223	1900	36.000	42	144.000	
MSP-51014	7.40		145		243	2050	38.000	44	152.000	
MSP-51016	8.42		165		263	2200	40.000	46	160.000	

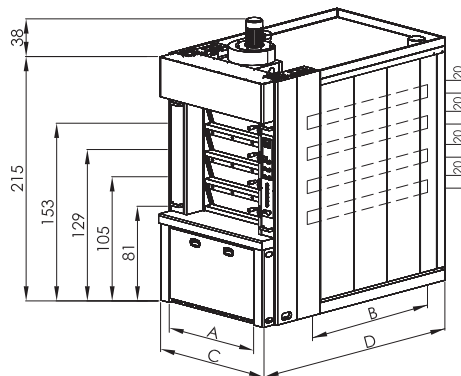

MSP 4

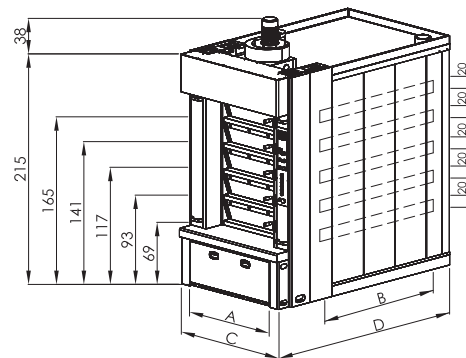

MSP 5

Modello - Model Modèle - Modelo		Gas Gaz	Gasolio - Gas-oil Fioul	GPL	Pellet	Modello - Model Modèle - Modelo		Gas Gaz	Gasolio - Gas-oil Fioul	GPL	Pellet
RING	PELLET	m <sup>3</sup> /h	L/h	L/h	Kg/h	RING	PELLET	m <sup>3</sup> /h	L/h	L/h	Kg/h

Tabella dei consumi medi - Average ovens consumption chart - Consommation moyenne - Tabla consumos medios

<b>MSR-40810</b>	<b>MSP-40810</b>	2.04	1.83	2.85	3.65	<b>MSR-50818</b>	<b>MSP-50818</b>	2.76	2.48	3.86	4.96
<b>MSR-40812</b>	<b>MSP-40812</b>	2.18	1.96	3.05	3.91	<b>MSR-50820</b>	<b>MSP-50820</b>	2.30	2.87	4.47	5.74
<b>MSR-40814</b>	<b>MSP-40814</b>	2.33	2.09	3.25	4.17	<b>MSR-51010</b>	<b>MSP-51010</b>	2.47	2.22	3.46	4.43
<b>MSR-40816</b>	<b>MSP-40816</b>	2.62	2.35	3.66	4.70	<b>MSR-51014</b>	<b>MSP-51014</b>	2.76	2.48	3.86	4.96
<b>MSR-40818</b>	<b>MSP-40818</b>	2.76	2.48	3.86	4.96	<b>MSR-51016</b>	<b>MSP-51016</b>	2.91	2.61	4.07	5.22
<b>MSR-40820</b>	<b>MSP-40820</b>	3.20	2.87	4.47	5.74	<b>MSR-60810</b>	---	2.40	2.15	3.36	---
<b>MSR-41010</b>	<b>MSP-41010</b>	2.33	2.09	3.25	4.17	<b>MSR-60812</b>	---	2.55	2.28	3.56	---
<b>MSR-41014</b>	<b>MSP-41014</b>	2.62	2.35	3.66	4.70	<b>MSR-60814</b>	---	2.69	2.41	3.76	---
<b>MSR-41016</b>	<b>MSP-41016</b>	2.76	2.48	3.86	4.96	<b>MSR-60816</b>	---	2.91	2.61	4.07	---
<b>MSR-50810</b>	<b>MSP-50810</b>	2.18	1.96	3.05	3.91	<b>MSR-60818</b>	---	3.05	2.74	4.27	---
<b>MSR-50812</b>	<b>MSP-50812</b>	2.33	2.09	3.25	4.17						
<b>MSR-50814</b>	<b>MSP-50814</b>	2.47	2.22	3.46	4.43						
<b>MSR-50816</b>	<b>MSP-50816</b>	2.62	2.35	3.66	4.70						

