

NOUVEAUTE
NEW

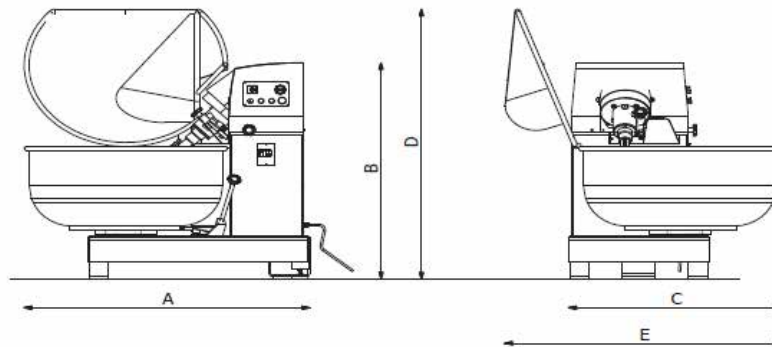

PAF120MM



PAFxMM - Version manuelle
PAFxMA - Version automatique

2 vitesses
 Panneau de commande électromécanique
 Grille de protection relevable
 Cuve inox libre
 Fourche en aluminium alimentaire
 Frein de cuve

Version automatique, passage automatique de la 1ère à la 2ème vitesse

PAFxMM - Manual model
PAFxMA - Automatic model

2 speeds
 Electromechanical control panel
 Liftable protection grid
 Stainless steel free bowl
 Aluminium fork
 Bowl brake

Automatic model, automatic transition from 1st to 2nd speed.

	PAF80Mx	PAF120Mx	PAF160Mx
Dimensions / Dimensions			
A mm	1300	1400	1500
B mm	1320	1320	1320
C mm	940	1020	1100
D mm	1550	1600	1650
E mm	1270	1350	1430
Poids / Weight			
Kg	460	480	500
Capacité / Capacity			
Coulage / Pouring (max) L	30	45	60
Farine / Four (max) Kg	50	80	120
Pâte / Dough (max)* Kg	80	120	160
Puissance / Power			
1ère vitesse / 1st speed kW	3	3	3
2ème vitesse / 2nd speed kW	4.5	4.5	4.5
Voltage / Voltage			
TRI - 400V - 50/60Hz			

*avec hydratation à 50% et sous réserve du respect de l'utilisation mentionnée / With 50% hydration and subject to the respect for the mentioned using