

FB08F-INOX

A poser sur table

3 cylindres :

- 1 cylindre de pré-laminage
- 2 cylindres de laminage

Châssis rigide indéformable

Tapis indéformables, qualité « whooltop »

OPTIONS

- Support à roulettes
- Tapis de sortie motorisé

FB08F-INOX

Table top model

3 cylindres:

- 1 roller for preliminary sheeting
- 2 rollers for sheeting

Undeformable stiff frame

Undeformable belts, « whooltop » quality

OPTIONS

- Rolling support
- Motorized outgoing belt

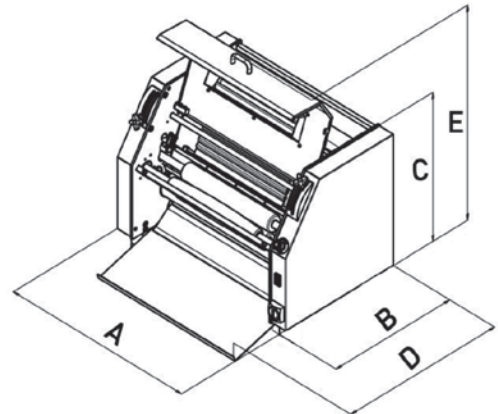
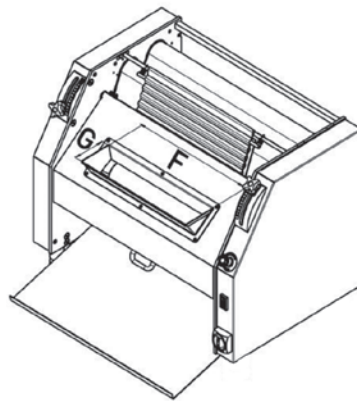
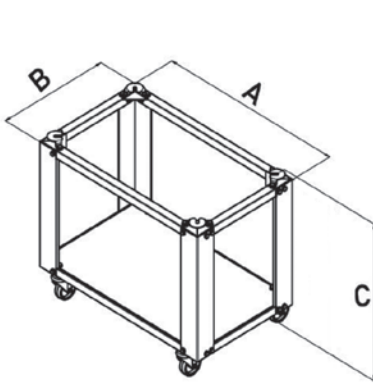
Dimensions / Dimensions

A mm / (support - A mm)	960 / 956
B mm / (support - B mm)	690 / 746
C mm / (support - C mm)	650 / 770
D mm	835
E mm	965
F mm	500
G mm	130
Largeur de travail / Working width	
mm	792
Poids / Weight	
Kg / (support - Kg)	202 / 30
Poids des pâtons / Dough piece weight	
Gr	De 50 à 1200
Production horaire / hourly production	
pièces / pieces	1200
Puissance / Power	
kW	1.1
Voltage / Voltage	
	TRI – 400V – 50/60Hz