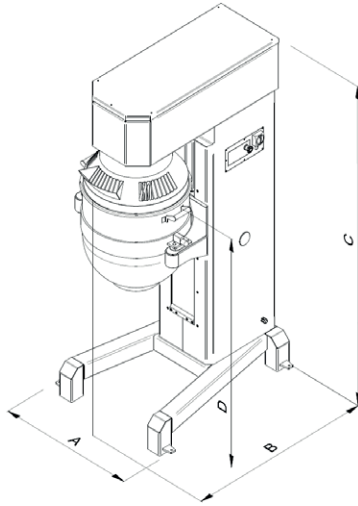

Fourni avec :
 Supplied with:

GAMME RENFORCÉE

STRENGTHED RANGE

BTx FH

 Variateur de vitesse
 Tableau de commande digital
 Minuterie

 Levage de cuve motorisé
 Cuve inox renforcée et outils inox
 Blocage de cuve
 Grille de sécurité rotative
 Bec verseur sur grille
 Mise à niveau réglable, patins anti-vibrations
 Pieds en inox peints

OPTIONS

- Equipements de réduction (à partir du BTA100FH)
- Racleur de cuve
- Chariot de cuve
- Elévateur de cuve
- Corps de machine en inox
- Tableau de commande tactile programmable
- Panneau de commande digital déporté

BTx FH

 Multi speed system
 Digital control panel
 Timer

 Motorised bowl lifting
 Stainless steel strengthened bowl and stainless steel tools
 Locking bowl
 Rotary safety grid
 Spout on grid
 Adjustable level, anti-vibration pads
 Stainless steel painted feet

OPTIONS

- Additional equipments (From BTA100FH)
- Bowl scraper
- Trolley for bowl
- Bowl lifter
- Stainless steel body
- Programmable touch screen control panel
- Remote digital control panel

BTA80FH
BTA100FH
BTA140FH

	BTA80FH	BTA100FH	BTA140FH
Capacité de la cuve / Bowl capacity			
Litres	80	100	140
Dimensions / Dimensions			
A mm	920	920	920
B mm	1250	1250	1250
C mm	2085	2085	2085
D mm	1490	1490	1490
Poids / Weight			
Kg	607	612	635
Puissance moteur / Motor power			
kW	4	4	4
Voltage / Voltage			
	TRI - 400V - 50/60Hz		