

ROTO AVANT

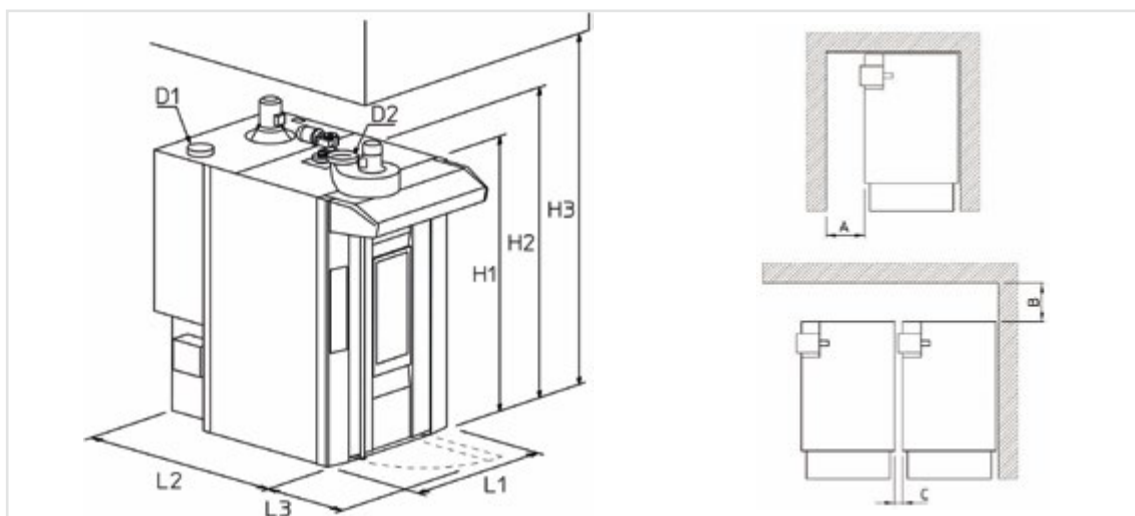

- Modular steam generator, with cascade elements with spheres (great steam production)
- Steamers with automatic feed
- Hood with potentiated exhaust fan and fat-collection tank
- Door with double glass and double closing
- Heat exchanger with armored heating elements.(SE)
- Standard rotation device with hook
- (for ergonomic reasons it's recommended for racks up to 100 kg full load)
- Electric board with extended cables to hang it on oven's sides
- Oven with burner on the right is available (optional)(Excluded 80120)
- Preset for automatic lifting group by lever (optional) (Excluded 80120)
- Racks height 1925 mm

POWER INLET	400V/3N~/50
FUME EXHAUST	Ø 200
STEAM EXHAUST	Ø 250



	Pan capacity		Pan size	Minimum door width	Weight	Voltage	SC version		SE version	
	n°	passo	mm	mm	kg	kW	kcal/h	kW	kW	
ROTO AVANT HR 6080	16	105	600x800	500	1450 SC 1400 SE	2,0	60.000	50,5	60,3	
	18	93	2x600x400							
ROTO AVANT HR 80100	16	105	800x1000	840	1900 SC 1850 SE	3,0	80.000	65,8	-	
	18	93								
ROTO AVANT HR 80120	16	105	800x1200	800	2220 SC 2150 SE	3,4	95.000	84,2	-	
	18	93	2x600x800							