



MARTE 20

planetaria
planetary mixer



YouTube

- Potente, robusta e flessibile grazie al controllo di velocità progressivo gestito da inverter
- Macchina adatta agli impieghi più gravosi e ideale per tutti coloro che vogliono qualcosa in più
- Dedicata al mondo della pasticceria è lo strumento ideale per chi vuole una macchina performante, affidabile, senza compromessi sulla quale poter contare sempre
- Il sistema ad inverter permette una regolazione precisa del numero di giri e sa adattarsi ad ogni lavorazione sia essa con frusta, spatola o uncino
- Solida struttura in carpenteria smaltata
- Pulsanti inox IP 67
- Timer 0-30 minuti e ∞
- 3 accessori di lavorazione inox facilmente sostituibili: spatola e gancio e frusta.

- *Powerful, sturdy and flexible thanks to the progressive speed control managed through an inverter*
- *A machine suited to heavy-duty activities, ideal if you are looking for extra performance*
- *Designed for the pastry sector, it is the ideal instrument for people who desire a high-performance, reliable and uncompromising machine offering guaranteed results*
- *The inverter-based system allows for finely tuning the number of revolutions and adapts to any processing method – with whisk, spatula or hook*
- *Solid enamelled body*
- *IP 67 stainless steel buttons*
- *0–30 minutes and ∞ timer*
- *3 s/steel tools easy to remove spatula, hook and whisk*

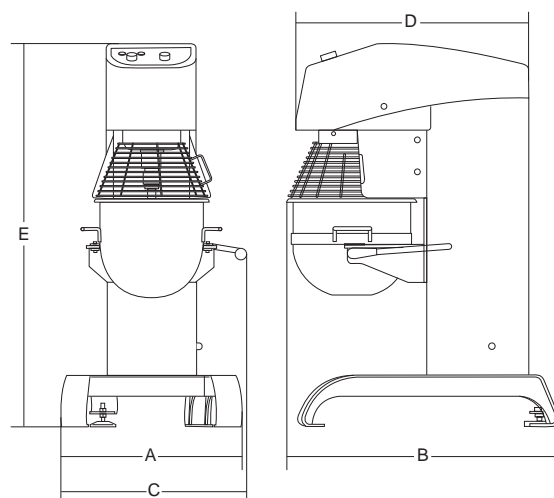

watt

r.p.m.

lt

mm

mm

mm

mm

mm

kg

mm

kg

Marte 20

1.500 1ph

120 - 400

20

ø 325x300

564

748

576

638

1189

130

824x675x1360

165