

Spindel periodisch
schmieren
graisser
périodiquement
grease the spindle
periodical

D (2,5:1)

Wenn durch Verschleiss der Luftspalt zu gross wird, muss die Schraube A gelockert und der Luftspalt neu eingestellt werden.

Si l'entrefer devient trop grand à cause de l'usure, le vis A doit être enlever et l'entrefer doit être ajuster de nouveau.

If by wearing the air gap becomes too big, the screw A has to be loosen and the air gap has to be set again.

Schmieren mit:

Graisser avec:

Lubricate with:

●=Molykote PG 65 Plastislip

■=Blasolube 472

▲=OKS 400

* ab Maschinen-Nr. B7A108001: 125296 statt 124114/124035

* à partir de no. de machine B7A108001: 125296 au lieu de 124114/124035

* from machine no. B7A108001: 125296 at place of 124114/124035

Beidseitig mit Schraube 6645
Spiel zwischen 0,3-0,5 einstellen

Ajuster le jeu entre 0,3-0,5 sur les
deux côtés, au moyen de la vis 6645

Adjust the backlash between 0,3-0,5
on both sides by the screw 6645

8.1

Maschinenkörper vorderes Gehäuse ECOSTAR
Corps de la machine carter avant ECOSTAR
Machine head front housing ECOSTAR

1/3

jur 16.12.2004

124125 d

A-A

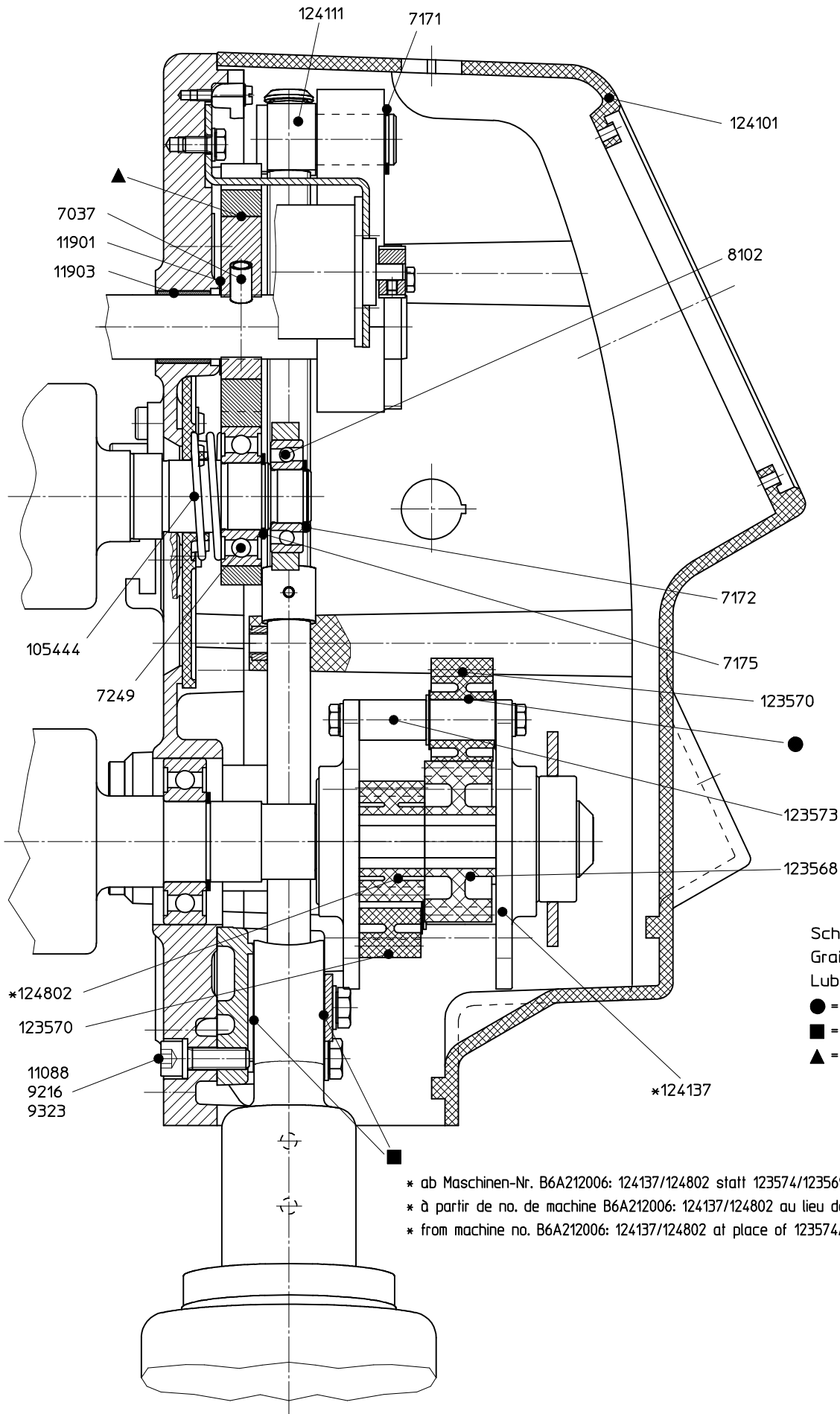

Schmieren mit:
 Graisser avec:
 Lubricate with:
 ● = Molykote PG 65 Plastistip
 ■ = Blasolube 472
 ▲ = OKS 400

* ab Maschinen-Nr. B6A212006: 124137/124802 statt 123574/123569
 * à partir de no. de machine B6A212006: 124137/124802 au lieu de 123574/123569
 * from machine no. B6A212006: 124137/124802 at place of 123574/123569

8.1

Maschinenkörper vorderes Gehäuse ECOSTAR
 Corps de la machine carter avant ECOSTAR
 Machine head front housing ECOSTAR

2/3

jur 16.12.2004

124125 d

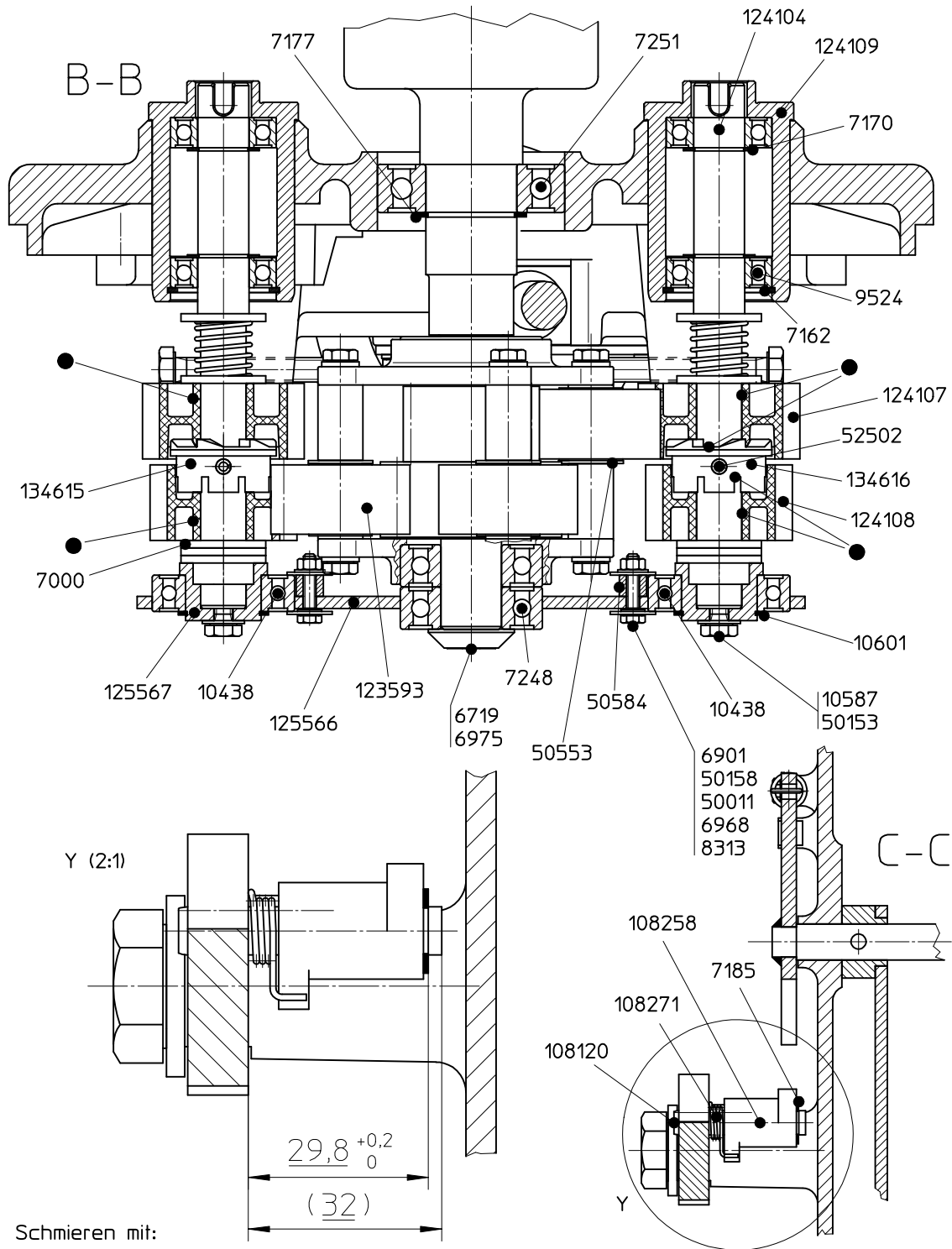

Schmieren mit:
 Graisser avec:
 Lubricate with:
 ● = Molykote PG 65 Plastislip

Schutzgitterstellung und Schaltsegmentstellung ohne Maschinentisch

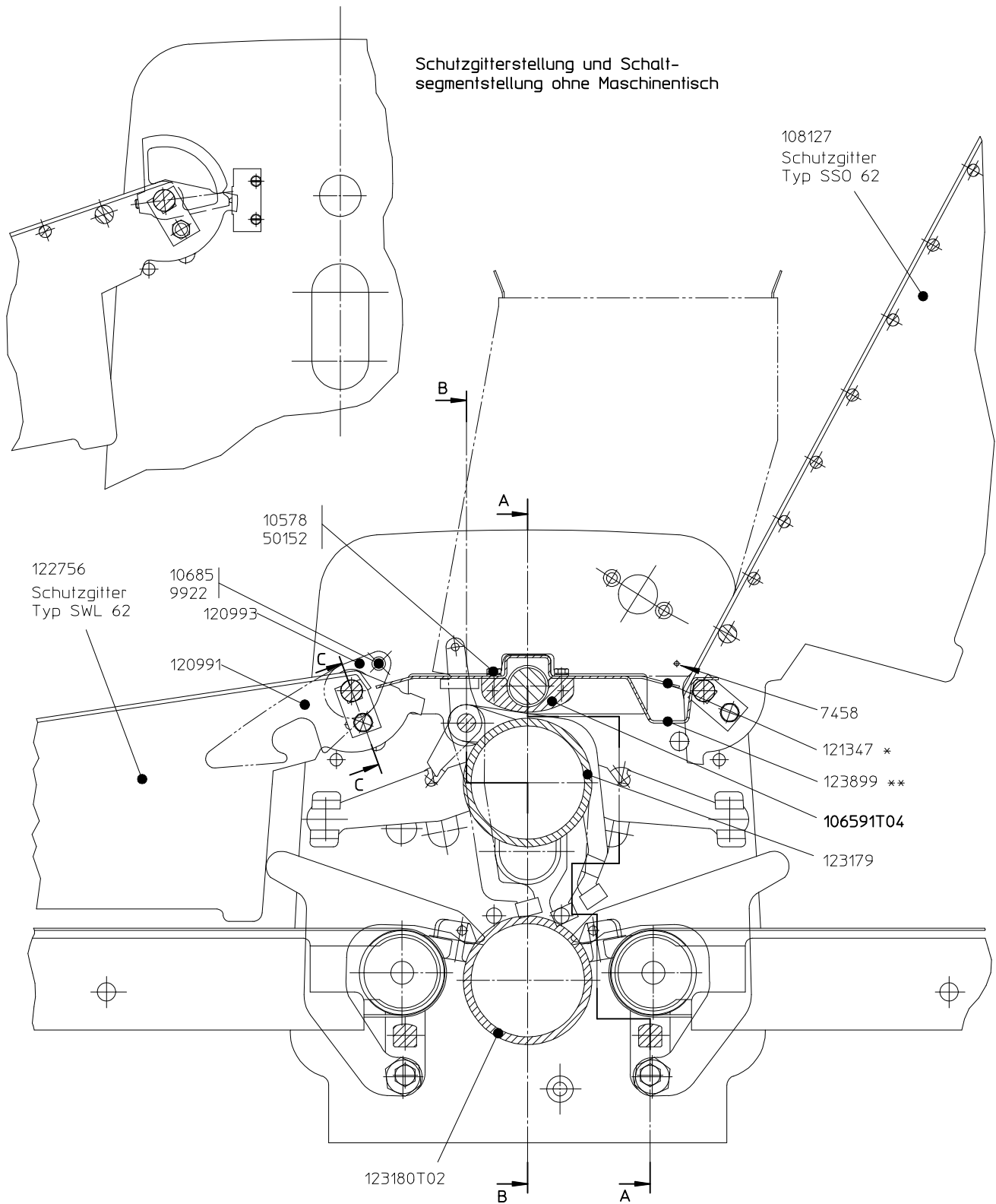

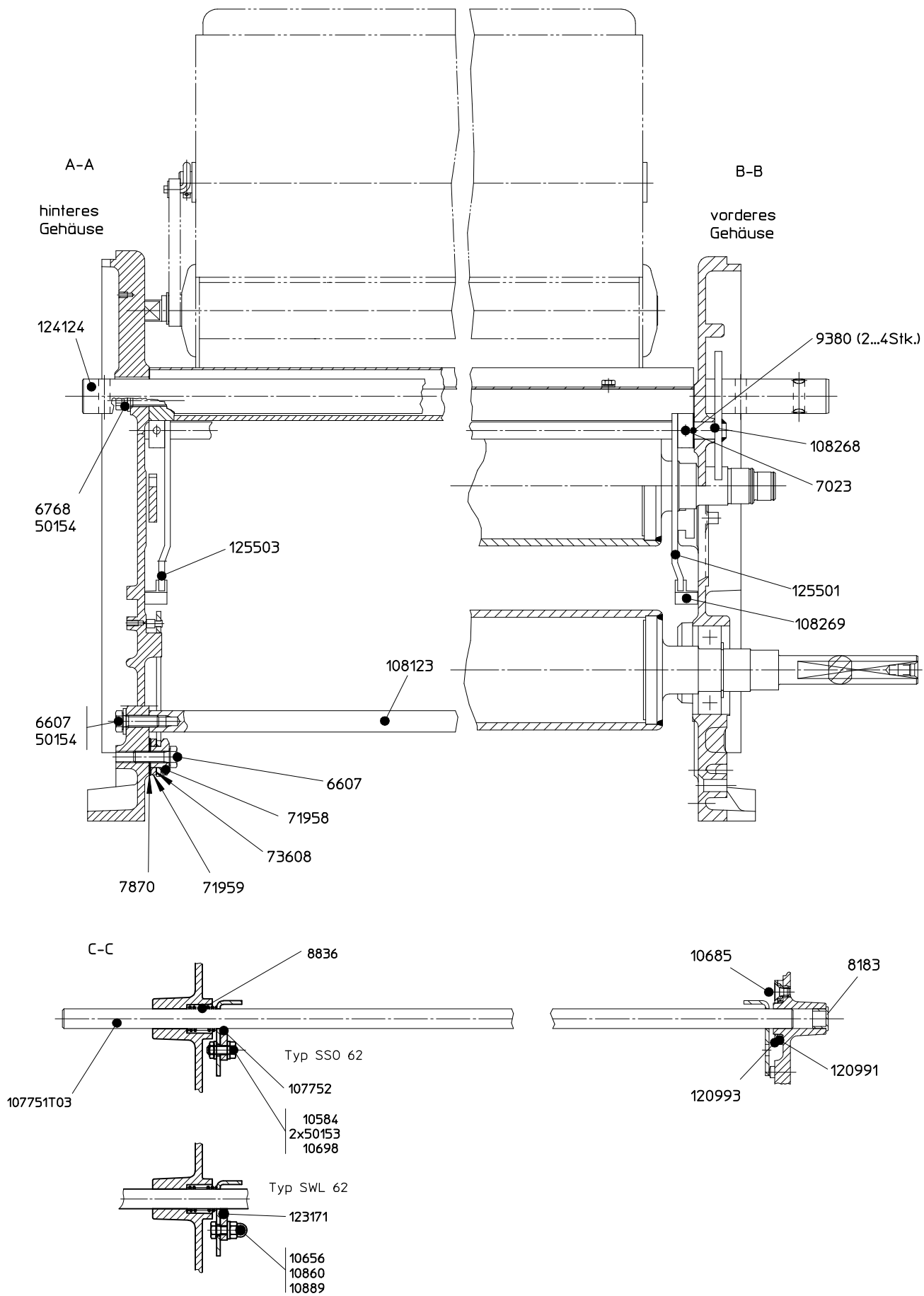

8.2

Maschinenkörper Zwischenteile Ecostar
 Corps de la machine pièces intermédiaires Ecostar
 Machine head intermediate parts Ecostar

2/3
 RZa 08.05.2006
 124126 f

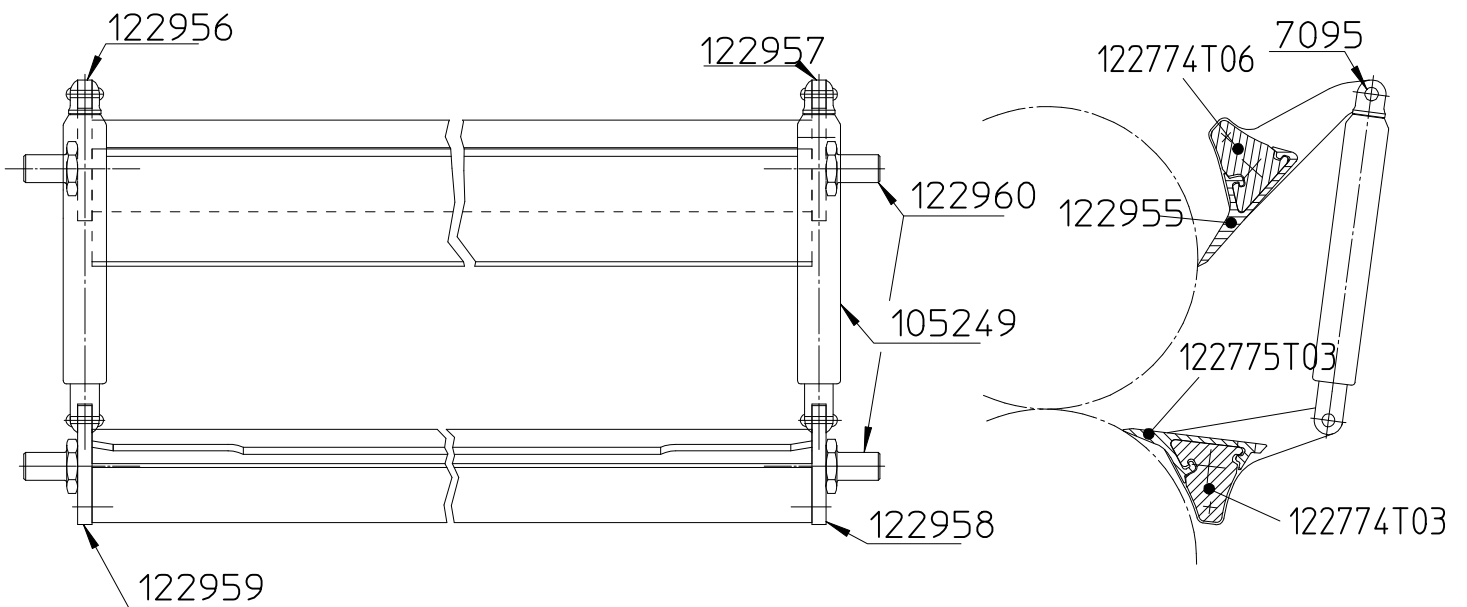
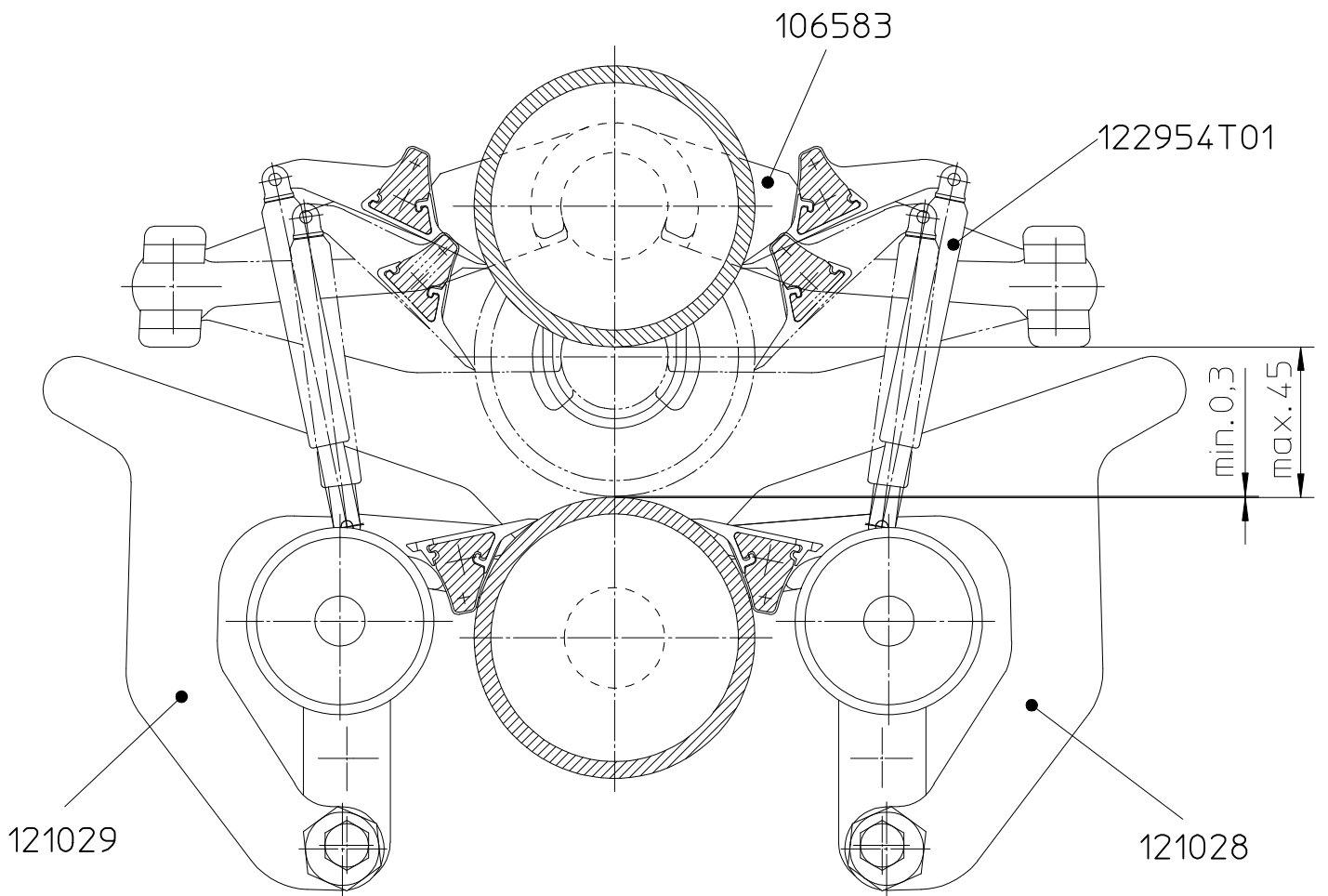

8.2

Maschinenkörper Zwischenteile Ecostar
 Corps de la machine pièces intermédiaires Ecostar
 Machine head intermediate parts Ecostar

3/3
 RZa 08.05.2006
 124126 f

B-B

Z (2:1)

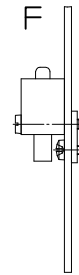
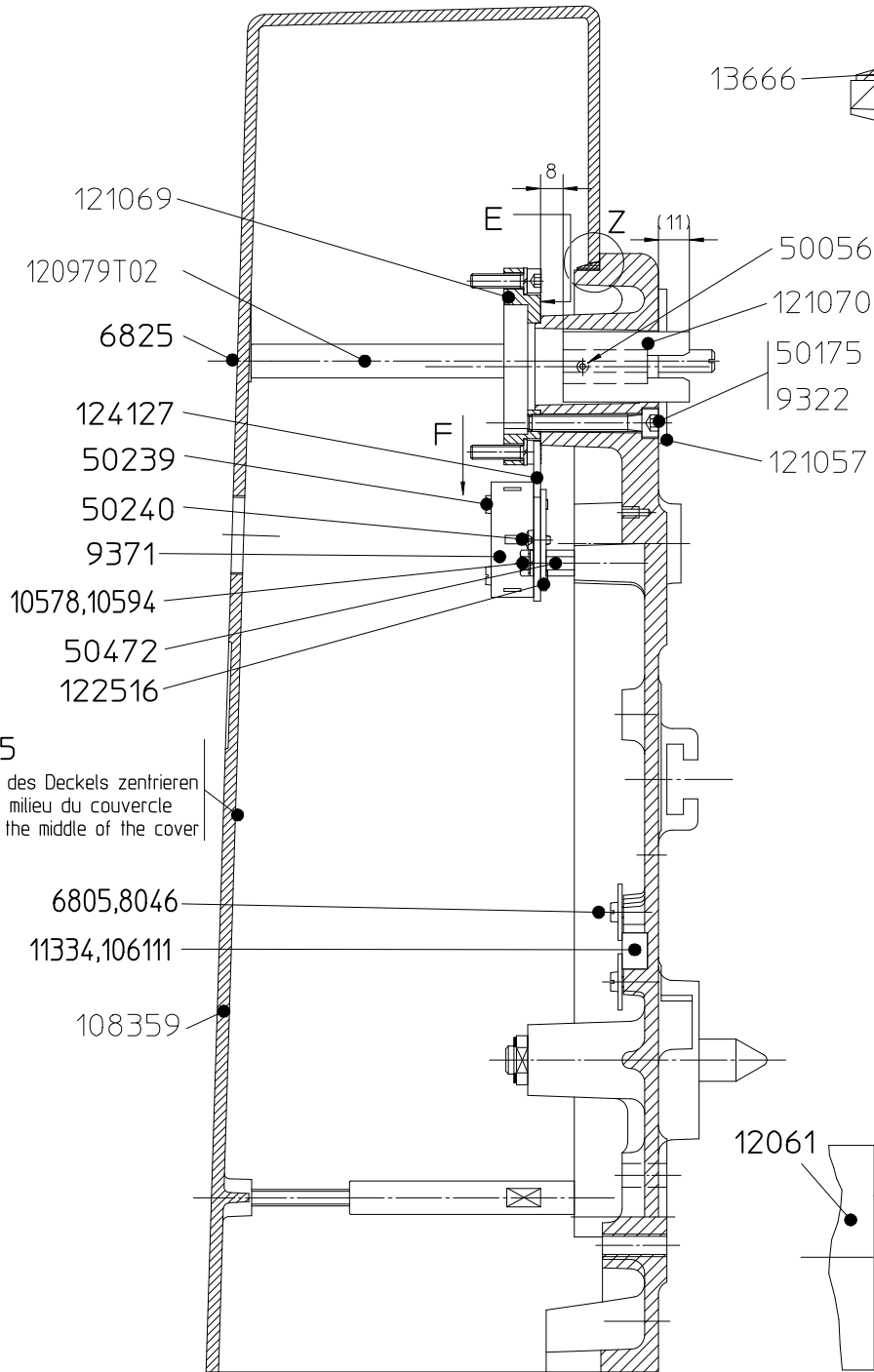
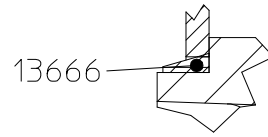

126235

In die Mitte des Deckels zentrieren
 Centrer au milieu du couvercle
 Centring in the middle of the cover

12061

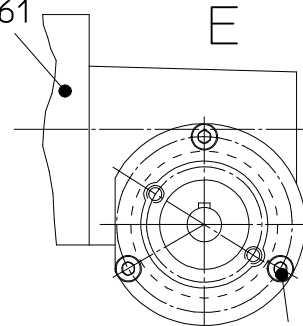

6724,6951

8.3

Maschinenkörper hinteres Gehäuse ECOSTAR
 Corps de la machine carter arrière ECOSTAR
 Machine head rear housing ECOSTAR

1/4
 jur 20.12.2004
 123177 b

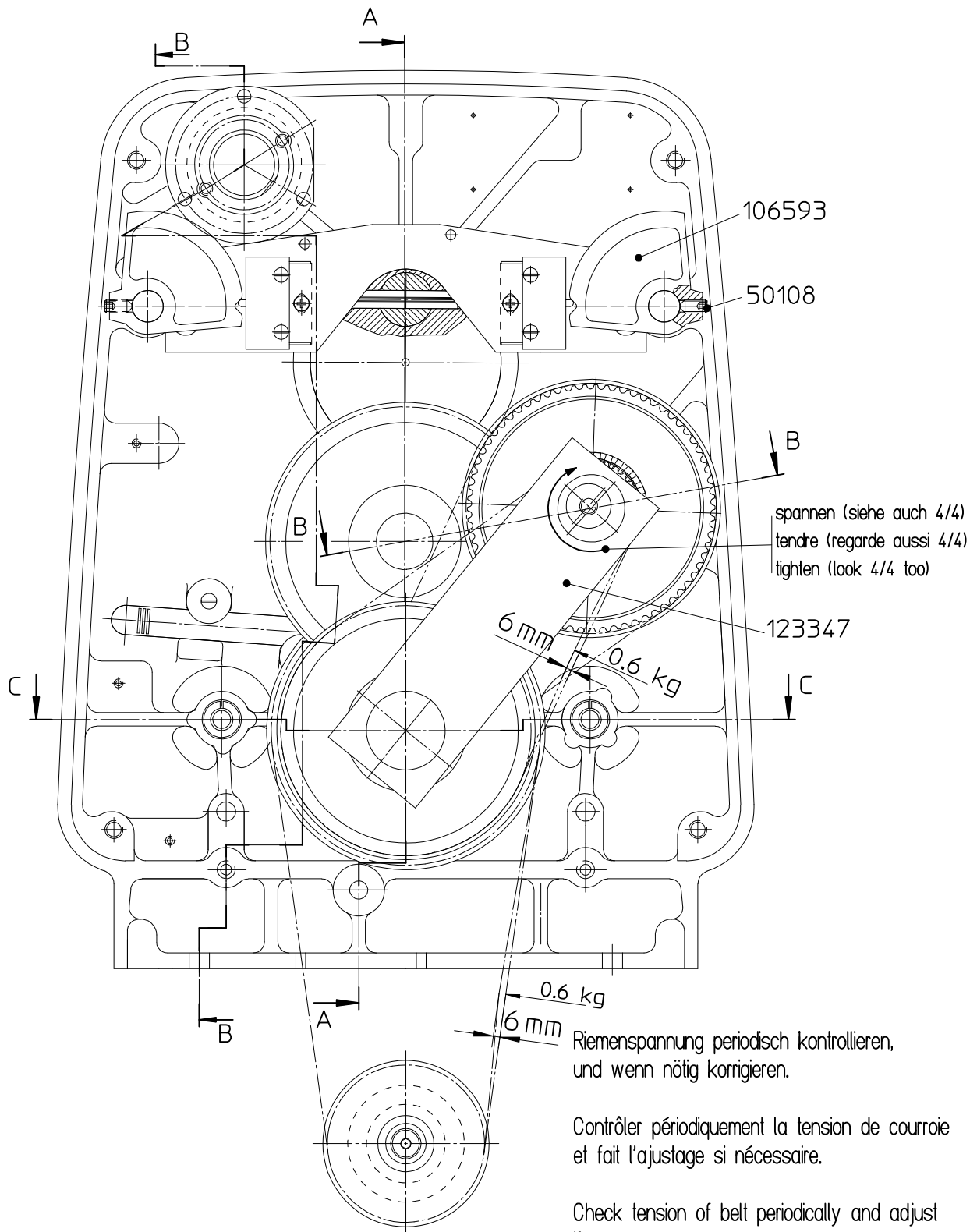

8.3

Maschinenkörper hinteres Gehäuse ECOSTAR
Corps de la machine carter arrière ECOSTAR
Machine head rear housing ECOSTAR

2/4

jur 20.12.2004

123177 b

A-A

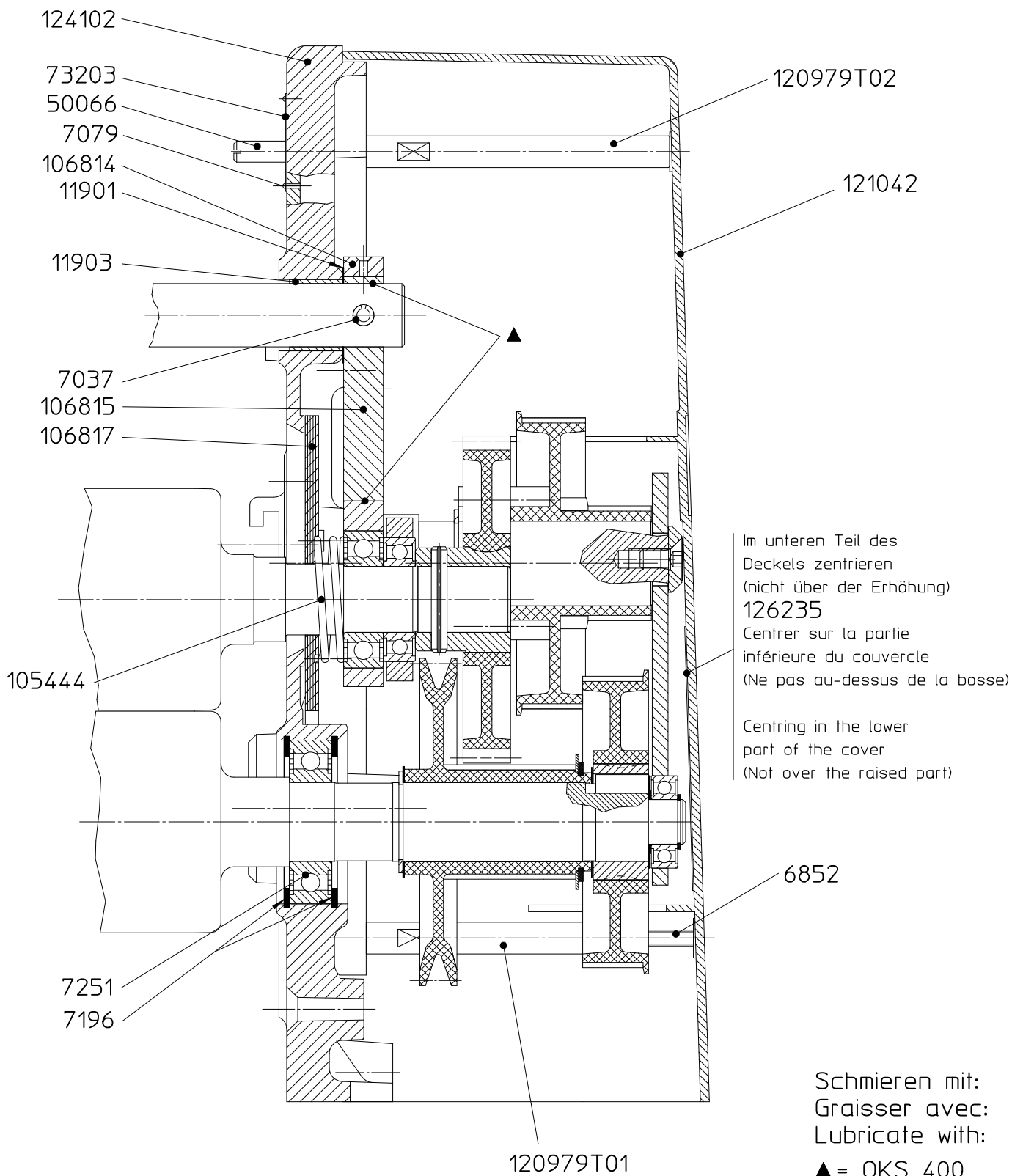

8.3

Maschinenkörper hinteres Gehäuse ECOSTAR
 Corps de la machine carter arrière ECOSTAR
 Machine head rear housing ECOSTAR

3/4

jur 20.12.2004

123177 b

8.3

Maschinenkörper hinteres Gehäuse ECOSTAR
 Corps de la machine carter arrière ECOSTAR
 Machine head rear housing ECOSTAR

4/4

jur 20.12.2004

123177 b

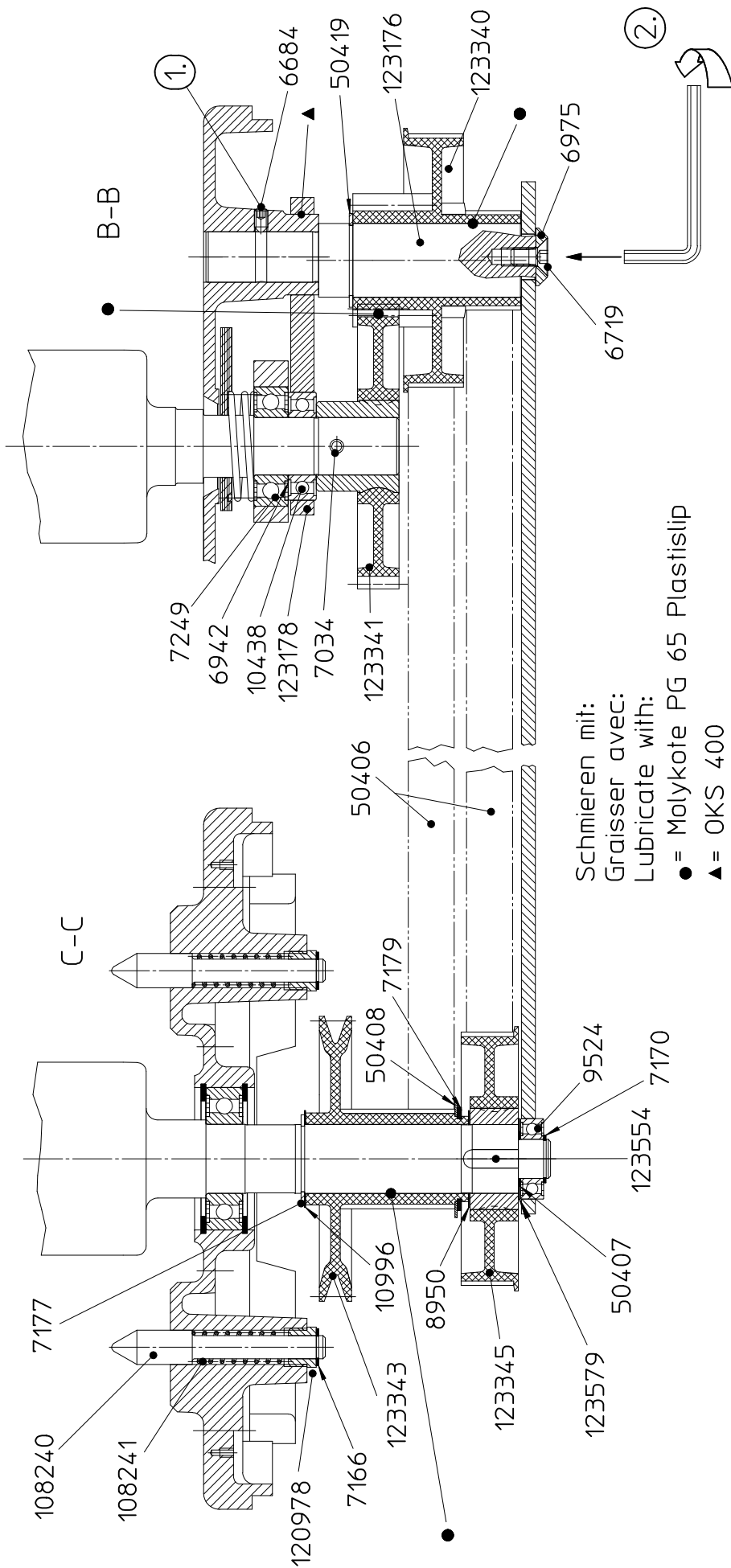

Schmieren mit:
 Graisser avec:
 Lubricate with:
 ● = Molykote PG 65 Plastislip
 ▲ = OKS 400

Riemen spannen
 tendre le courroie
 tighten the belt

① Schraube lösen
 deviser la vice
 loose the screw

② Mit Schlüssel drehen
 tourner avec le clé
 turn with spanner

ACHTUNG:
 Zu starke Riemen Spannung kann die Lager zerstören. → Siehe auch Hinweisschild
 (Starke Erwärmung!) (126235) im hinteren Deckel

ATTENTION:
 Tension trop forte peut détruire les patiers. → Voir aussi plaque indicatrice
 (Echauffement fort!) (126235) en couvercle arrière

ATTENTION:
 To hard tension can damage the bearings. → See also information sign
 (Heating!) (126235) in rear cover