



*K12 Premium*

*K24 Premium*

*K50 Premium*



**K12, K24 & K50 PREMIUM, the tempering machine**



# K12, K24 & K50 PREMIUM

## THERMIC SELF-BALANCING

Automatic control system to operate the temperature in accordance with the quantity of product inside the machine.

## SHEET RESISTANCE HEATING SYSTEM

The patented sheet resistance heating system allows for precise chocolate temperature control avoiding an unpleasant exit from the tempering.

## SWITCHING OFF

The machine doesn't stop immediately at the signal but detects automatically the exit from the tempering before the interruption of the operation. The restart of the service is thus facilitated.

## HEATED FLAT TABLE

- The vibration eliminates air which allows the chocolate to be packed into the moulds.
- Easily removable for cleaning.

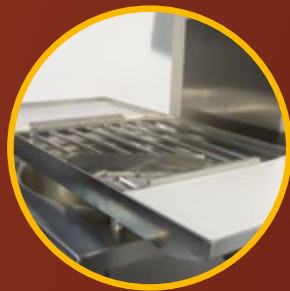

## TEMPERATURE CONTROL

Due to the viscosity in chocolate, it is very difficult to monitor changes in the temperature. In the K12, K24 and K50 PREMIUM an algorithm controls the probes that detect the temperature within a tenth of degree accuracy and keeps steady temperature at the heart of the chocolate.

## DELAYED START

It is possible to program start after a preset period to have melted or temper chocolate when you need it.

## AUGER SCREW

The auger screw is made in stainless steel which helps to prevent wear over time and its movement can be reversed to facilitate the cleaning.

## FURTHER ADVANTAGES

- Programmable volumetric pedal dispenser.
- Rapid emptying of the tank for cleaning.
- Back pipe for chocolate outflow.

## Magic Carpet: Coating Belt for Partial or Total Covering\*

- 3 zones band to totally or partially enrobe the products, its speed can be adjusted by a speed variator. The output zone (equipped with cutting tails) as well is adjustable in speed and height to avoid waste. The coating area has an adjustable vibration system for dripping the chocolate.
- Equipped with anti-congealing lamps for the chocolate that flows back in the tank.
- It is possible to stop the loading area of the trolley for precise positioning of the product.
- Equipped with release system for cleaning of the part that is dirty of chocolate.
- Air flow, for removing the chocolate in excess, with adjustable nozzle.
- Partial enrobing device available in 2 versions, single shower or double shower for an impeccable partial enrobing.
- Equipped with accessory for a uniform stracciatella enrobing.
- The «Easy Cut System» allows for a quick and easy paper cut avoiding any slowdown in the couverture cycle or damage to the coating belt.
- Equipped with a special device to perfectly tighten the paper.
- Equipped with a special device to adjust the alignment of the conveyor belt to the machine to be perfectly straight.
- Clutch to avoid the break of the conveyor belt during the turn on.
- Do-it-yourself replacing of the metallic net possible thanks to the patented quick system
- Equipped with stainless steel tap easy to be adjusted to supply the arc diffuser to do the total enrobing.
- Available optional for partial enrobing of the product made of a diffuser, diffusing pipe and net lowering structure.
- Available optional heated casting plate equipped with interchangeable nozzle support. Customized number of nozzles depending on user's need.



\* available also for K12.

**THE BUSINESS...  
AT HAND!**



***K12*** Premium

***K24*** Premium

***K50*** Premium

**Bravo** stays at the professionals side and for this reason we have designed **K12, K24** and **K50 PREMIUM** and **MAGIC CARPET PREMIUM**, to let realize the high-quality professional chocolate tempering in an easy and fast way.

## Technical Features

		K12 air	K24 air	K50 air	K50 water
Max tank capacity	kg	12	24	50	50
Suggested min quantity	kg	6	8	8	8
Max power	kW	3	4,6	6,4	6,4
Medium power*	kW	1,7	2,3	3	3
Voltage / Phase / Frequency		400 V / 3+N / 50 **			
Absorption	Amp	4,3	8	12	12
Power socket	Amp	16			
Freon		R449A			
Cooling system		AIR	AIR	AIR	WATER
Width [A]	cm	42,5	54,5	54,5	54,5
Width with flatboard [B]	cm	80,5	80,5	80,5	80,5
Width with Magic Carpet [C]	cm	178	178	178	178
Depth [D]	cm	76	76	90,5	76
Height floor chocolat [E]	cm	99	99	99	99
Height Magic Carpet/Vibrating table [F]	cm	105,5	105,5	105,5	105,5
Magic Carpet worktop width	cm	25	25	25	25
Total height [G]	cm	155	153	153	153
Weight	kg	140	173	190	-
Magic Carpet weight	kg	60	60	60	60
Vibrating table weight	kg	12	12,5	12,5	12,5

\* only for the machine in the maintenance phase and without external users  
 \*\* also available in single phase 230V / 1 + N / 50

## CHOCOLATE K12 - K24 - K50

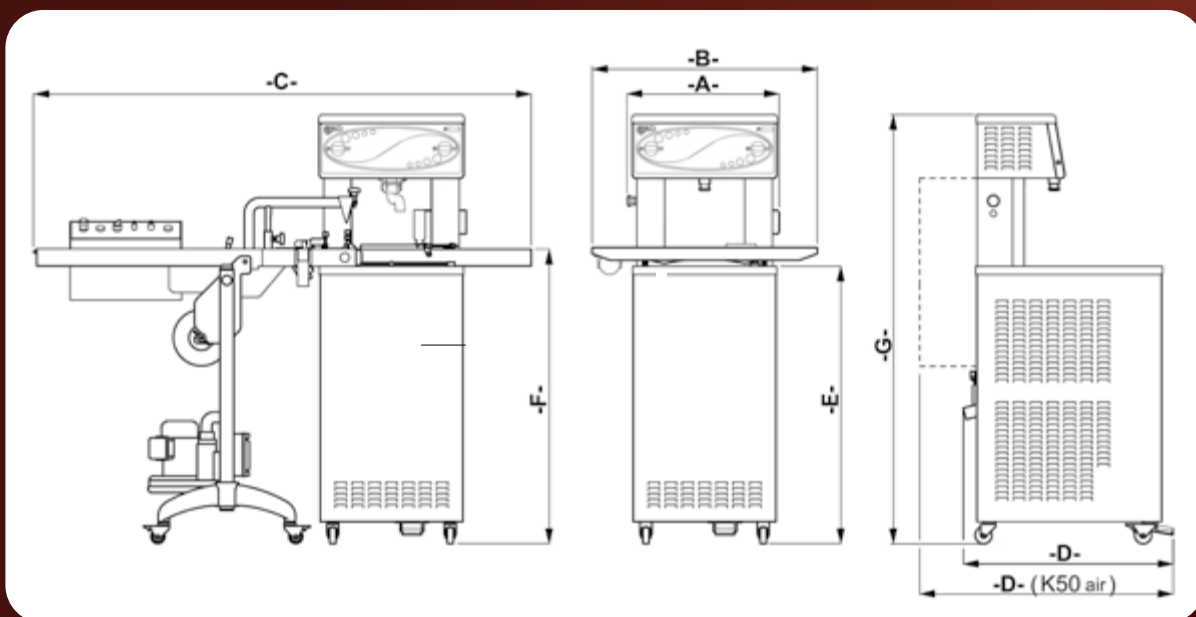

**HEADQUARTERS**  
**Bravo S.p.A.**  
 Montecchio Maggiore - Vicenza, Italy  
 Tel.: +39 0444 707700  
 Email : info@bravo.it  
[www.bravo.it](http://www.bravo.it)

**Bravo all over the world**  
[info@bravofrance.fr](mailto:info@bravofrance.fr)  
[info@bravodeutschland.de](mailto:info@bravodeutschland.de)  
[info@bravonorthamerica.com](mailto:info@bravonorthamerica.com)  
[info@bravo.asia](mailto:info@bravo.asia)