

Pastomaster HE

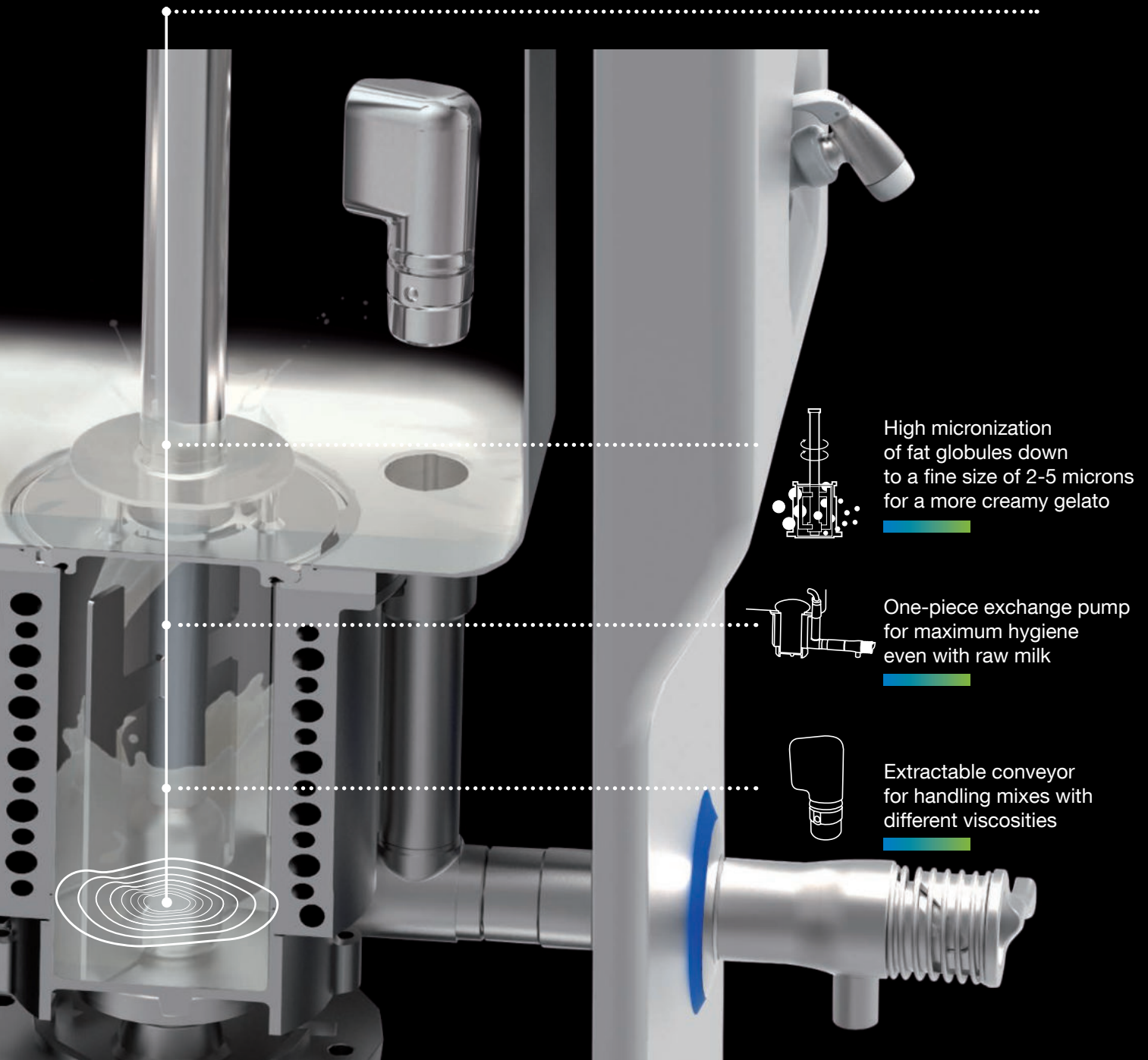



ADAPTIVE EXCHANGER PUMP



High micronization of fat globules down to a fine size of 2-5 microns for a more creamy gelato

One-piece exchange pump for maximum hygiene even with raw milk

Extractable conveyor for handling mixes with different viscosities

THE INTELLIGENT TECHNOLOGY THAT TAKES SPECIAL CARE OF YOUR MIX

Pastomaster HE
High Efficiency.
Unique.



Pasteurization

Controlled heat treatment discovered in 1864 by French scientist Louis Pasteur to sanitize food by killing pathogenic microbes without causing the deterioration of vitamins and proteins. In other words, purifying while preserving the food's nutritional value, taste, and aroma.

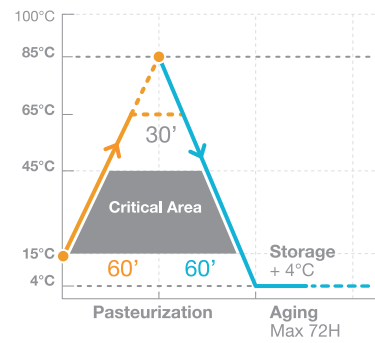

GELATO AND YOGURT MIXES

9 basic programs to produce all kinds of basic and complete gelato mixes and yogurt



High Pasteurization
85°C

The most frequently used, for maximum guarantee of food safety.



Low Pasteurization
65°C

A more delicate cycle, to respect ingredient taste and texture.



Intermediate Pasteurization

Choose any pasteurization temperatures between 65°C and 95°C.



Chocolate Pasteurization
90°C

For chocolate mixes. This cycle melts chocolate perfectly while bringing out its aroma.



Cooling Aging

Cooling at 4°C, storage, and aging, without heating.



Sugar Syrup

To produce the syrup used in water-based mixes.



Inverted Sugar

To produce the sweetener used to reduce solids without eliminating sweetness.



Liquid yogurt

To produce drinkable yogurt with milk and cultures.



Dense yogurt

To produce an excellent yogurt that is dense and creamy.



> SAUCES*



Programs to produce 7 sauces that together with the base mixes can be used to quickly produce classic gelato flavors:

- Cream Sauce
- Zabaione Sauce
- Cocoa Sauce
- Fruit Sauce
- Chocolate Sauce
- Citrus Sauce
- Lemon Sauce

*Pastomaster 60 HE models only



> SPECIALTIES*



Programs to produce 6 artisanal specialties to offer in your gelato shop:

- Pudding
- Panna Cotta 1
- Panna Cotta 2
- Bavarian cream
- Semifreddo base
- Italian Meringue

*Pastomaster 60 HE models only



> FREE PROGRAMS



There are 5 free programs so that the gelato artisan can personalize and memorize proprietary pasteurization cycles.



CHEESE



8 programs to produce:

- Ricotta cheese
- Robiola cheese
- Soft cheese
- Hard cheese
- Special cheese
- Cooked whey
- Bulk starters
- Whey starters



MILK



Programs to produce:

- Heat treatment
- Scheduled heat treatment
- Low milk pasteurization (Low-temp)
- High milk pasteurization (High-temp)



The machine includes a recipe book with detailed recipes and information on ingredients that can be downloaded by scanning the QR Code on the front of the machine.



PERFORMANCE

Exchange Pump

The ingredients are mixed and pasteurized inside the exchange pump cup, which is located on the tank bottom. This exclusive, patented Carpigiani technology guarantees:

High micronization: the millimetric cup-beater coupling and the different mixing speeds reduce the fat globules to particularly fine sizes, from 2 to 5 microns, for a gelato that is more creamy and stable.

Superior efficiency allows working even with minimum batches without the risk of burning the mix. Furthermore, the original dry bain-marie system avoids product buildup.

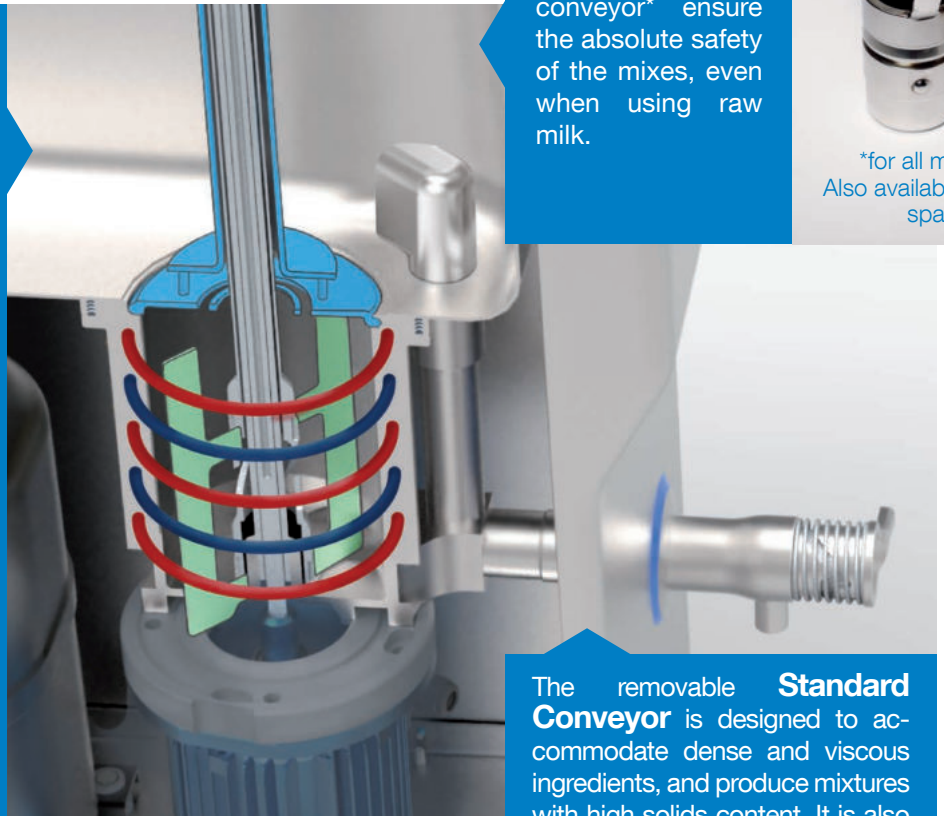

Raw Milk

The one-piece exchange pump, the new spigot design, and the specific conveyor* ensure the absolute safety of the mixes, even when using raw milk.



*for all models. Also available as a spare part

The removable Standard Conveyor

is designed to accommodate dense and viscous ingredients, and produce mixtures with high solids content. It is also ideal for the production of sauces and cheeses. (The Removable Standard Conveyor is square shaped with smaller diameter for Pastomaster 60 and larger diameter for Pastomaster 120).

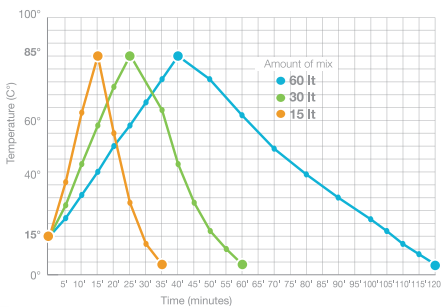

Pastomaster 120 HE

The cooling system is divided into three parts, operating according to the quantity of mix being processed:

- Min 30 – 60 liters
- Med 60 – 90 liters
- Max 90 – 120 liters

Cycle times

The thermal exchange per liter of mixture, heating to 85°C and cooling to 4°C, is extremely rapid: less than 2 minutes on the 60 HE model and less than 1 minute on the HE 120. With this technology, the energy consumption and the pasteurization times are directly proportional to the amount of mix being produced.



High Power*

Optional feature that allows you to save up to 20%** on heating times without increasing total energy consumption.

* Only available on Pastomaster 60 HE and Pastomaster 60 HE P models. Must be ordered at time of purchase. ** Compared to the standard version



CONVENIENCE

New solutions
for maximum
ease of use



Lid and exchange pump

Brand new design lid, easy to assemble and disassemble. Thanks to the exchange pump, by opening the lid you can add the ingredients (while the mix is being stirred) working in complete safety.

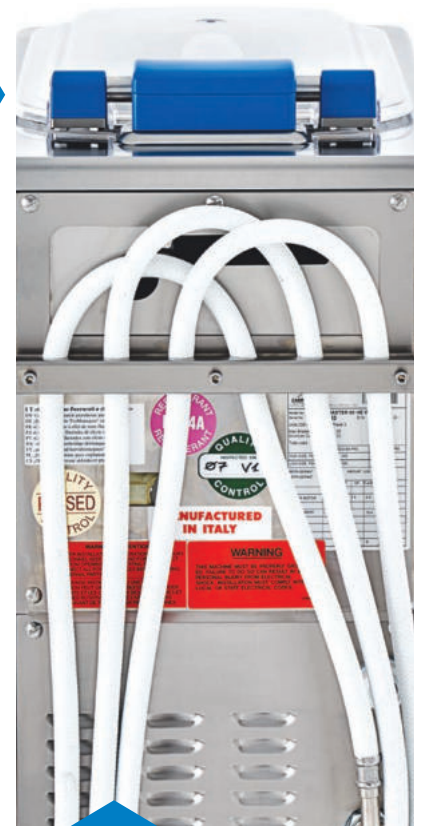

Hose bracket

Thanks to the bracket located on the back of the machine it is possible to situate the water hoses so that they remain raised from the ground, thus facilitating easy movement and cleaning of the floor.

Mixture Transport Kit

Optional kit designed to hygienically transfer mixtures.



Bucket shelf

Optional extra made of steel. Removable for easy washing.



Water Filling*

New optional extra to **dispense the precise quantity of water** required by the recipe and/or for cleaning, saving time and avoiding quantity errors.



QR CODE

Scan the **QR Code** on the front of the machine to access the most up to date equipment information: Instruction Manual, Carpi Care kit & Carpi Clean kit.

*for all models. Must be ordered at time of purchase



SAVINGS

Reduced consumption of water

high efficiency

Carpigiani HIGH EFFICIENCY technology, equipped with high-efficiency motors and high-performance condensers, providing maximum efficiency during pasteurization of the mixes. Pastomaster HE ensures generous savings in water consumption, **up to 30%** compared to RTX pasteurizers.

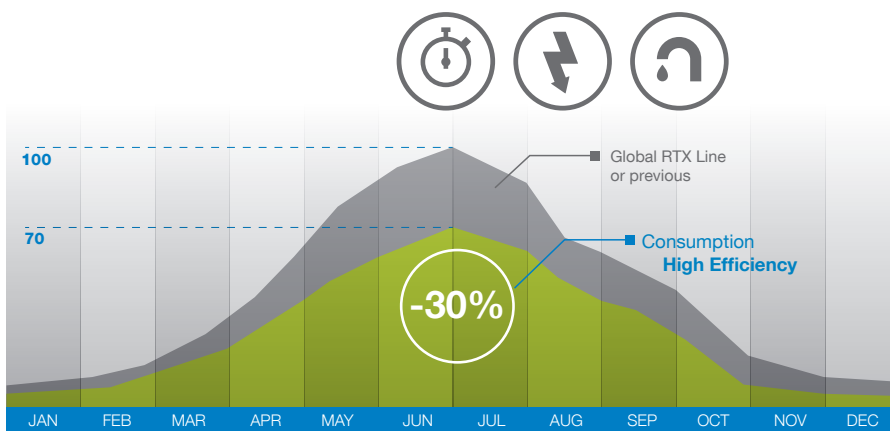

SAFETY

More operational safety and increased control of production



Ergonomic design

Increased accident prevention with more rounded corners.

Lid

To avoid the spatter of boiling liquid, the beater stops moving if the lid is lifted when the mix is hotter than 50°C.

Blackout and Water supply cutoff

After an electrical blackout or interruption of the water supply, if the temperature-time parameters can guarantee that the mix has not suffered the pasteurizer resumes the current program. Otherwise it automatically starts a new full pasteurization cycle, alerting the user with a message on the display.

During processing, when the temperature exceeds 50°C the display turns red to alert the operator that inside the machine there are heated products. This visual cue helps prevent improper operations with hot products.



With **TEOREMA** you can monitor the machine via internet, PC, tablet, and smartphone. Technical service is facilitated thanks to the ability to remotely perform controls and diagnostics.

Pastomaster 60 HE

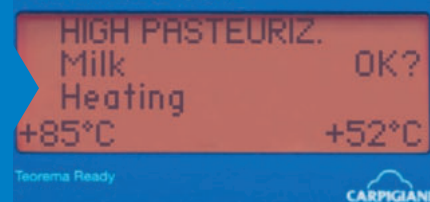

Teorema Ready





HYGIENE

Facilitated cleaning,
guaranteed hygiene

Temperature-controlled spigot

The mixture circulates continuously inside the spigot ensuring its correct operating temperature both during pasteurization and in the storage/aging phase.



Spigot always clean

The new shape makes it possible to wash the mix spout at any time, during any stage of production.

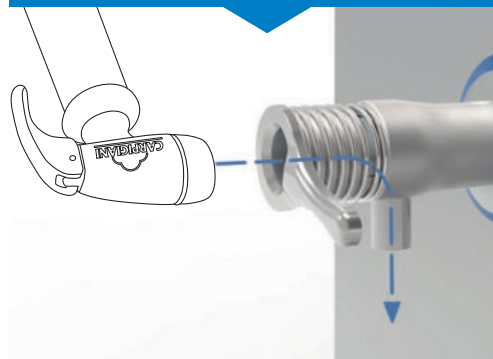

Total cleaning

The new spigot, the removable conveyor, and the one-piece cup allow for complete and easy cleaning of the machine.



The **new stainless** steel wheels can withstand frequent washing even with the most aggressive detergents.

The **new stainless steel** sprayer is located on the front of the machine for an easier cleaning of the cylinder and the chute, and to avoid cross maneuvers with the door. The sprayer can also be locked to facilitate handling during use.

Even the cleaning of the surfaces is quick because the **Scotch-Brite treatment** of the stainless steel makes it resistant to stains and fat residues.

Carpi Care kit



request them from your dealer to always keep your machine hygienically perfect.

Carpi Clean kit



Pastomaster 60 HE

Pastomaster 120 HE



Production specifications

|  | Production cycle* | Tank Capacity | | Yogurt Production | | Sauce Production** | | Specialty Production | |
|---|-------------------|------------------|-----|-------------------|----|--------------------|----|----------------------|----|
| | liters / minutes | min - max liters | | min - max kg | | min - max kg | | min - max kg | |
| Pastomaster 60 HE | 60 / 120 | 15 | 60 | 15 | 45 | 15 | 45 | 15 | 45 |
| Pastomaster 60 HE P | 60 / 120 | 15 | 60 | 15 | 45 | 15 | 45 | 15 | 45 |
| Pastomaster 120 HE | 120 / 120 | 30 | 120 | 30 | 90 | - | - | - | - |

* Hourly production rates vary according to the ingredients used. ** For the cocoa sauce the maximum quantity allowed is 15 kg.

Production rates refer to a room temperature of 25°C and a water temperature of 20°C in the condenser.

Technical Specifications

|  | Speed Mix | Electrical supply* | | | Rated power input | Fuse | Condenser | Size cm (width and height at the base) | | | Net weight |
|---|-----------|--------------------|----|----|-------------------|------|-----------|--|---------|----------|------------|
| | no. | Volts | Hz | Ph | kW | A | | Width W | Depth D | Height H | kg |
| Pastomaster 60 HE | 5 | 400 | 50 | 3 | 7 | 16 | Water | 35 | 90 | 105 | 165 |
| Pastomaster 60 HE P | 5 | 400 | 50 | 3 | 11,2 | 20 | Water | 35 | 90 | 105 | 165 |
| Pastomaster 120 HE | 5 | 400 | 50 | 3 | 11,2 | 20 | Water | 65 | 90 | 105 | 269 |

* Other voltages and cycles are available with surcharge.

The above dimensions and weight refer to the water cooled version.

The Pastomaster HE machines are made by Carpigiani according to a Certified Quality System UNI EN ISO 9001.

All specifications mentioned must be considered approximate. Carpigiani reserves the right to modify, without notice, all parts deemed necessary.



Via Emilia, 45 - 40011 Anzola dell'Emilia - BOLOGNA, Italy - T. +39 051 6505111 - info@carpigiani.it

an Ali Group Company



The Spirit of Excellence