



# POTATO PEELER PI-30

30 kg / 66 lb load per cycle.



Outlet door dimensions  
Door height: 130 mm  
Door width: 160 mm

### External dimensions (W x D x H)

- ✓ Width: 622 mm
- ✓ Depth: 760 mm
- ✓ Height: 1002 mm

### External dimensions with stand

- ✓ Width with stand: 546 mm
- ✓ Depth with stand: 760 mm
- ✓ Height with stand: 1255 mm

Net weight: 60 kg

### AVAILABLE MODELS

1000630	Potato peeler PI-30 230-400/50/3N
1000631	Potato peeler PI-30 230/50/1
1000632	Potato peeler PI-30 220-380/60/3N
1000633	Potato peeler PI-30 220/60/1
1000638	Potato peeler PI-30 120/60/1
1000997	
1000998	

\* Ask for special versions availability

## SALES DESCRIPTION

Stainless steel construction commercial potato peeler. Also suitable to peel carrots and other similar products. 0-6 min timer. Removable turntable for easy cleaning.

High capacity and production owing to lateral stirrers covered with silicon carbide abrasive (approved by NSF). Aluminium base plate lined with silicon carbide abrasive (approved by NSF). Construction in stainless steel.

- ✓ Auto-drag of waste to the drain.
- ✓ Energy efficiency thanks to engine optimisation.
- ✓ Lifiable transparent cover, complete with locking and safety device.
- ✓ Aluminium door with hermetic seal and safety device.
- ✓ Waterproof control board (IP65): Improved reliability against moisture and water splash.
- ✓ Water inlet system with non-return air break.
- ✓ Auxiliary contact for external electric valve.
- ✓ 0-6min timer and possibility of continuous operation.

## OPTIONAL

- Stainless steel floor stand complete with filter with no-foam feature.

## ACCESSORIES

- Stands for potato peelers
- Filters for potato peelers M / PI / PES

## SPECIFICATIONS

Hourly production: 600 kg / 720 kg  
Capacity per load: 30 kg  
Timer (min-max): 0' - 6'  
Total loading: 730 W



DYNAMIC PREPARATION  
COMMERCIAL POTATO PEELERS

product sheet  
updated 22/07/2024



# POTATO PEELER PI-30

30 kg / 66 lb load per cycle.



DYNAMIC PREPARATION  
COMMERCIAL POTATO PEELERS

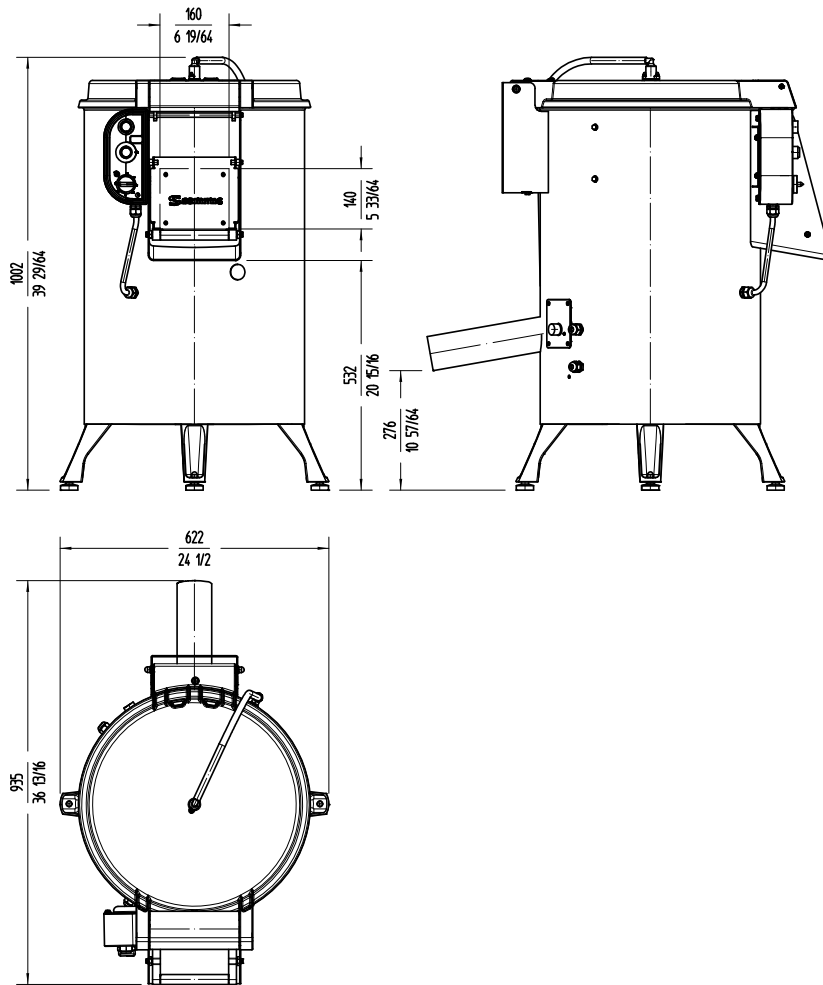

**sammic** | [www.sammic.com](http://www.sammic.com)  
Food Service Equipment Manufacturer

Polígono Basarte, 1. phone +34 943 15 72 36  
20720 Azkoitia, Spain [sales@sammic.com](mailto:sales@sammic.com)



Project	Date
Item	Qty
Approved	

product sheet  
updated 22/07/2024