



PEELER & SALAD DRYER PES-20

2 in 1: potato peeler & salad dryer.



- ✓ Capacity per operation (lettuces): 2-3
- ✓ Equipment: abrasive plate: 1

Draining function

- ✓ Drainer hourly production: 20 kg
- ✓ Production/hour (salad spinner): 19.5 l
- ✓ Draining basket: 1

General features

- ✓ Timer (min-max): 0' - 6'
- ✓ Total loading: 550 W

External dimensions (W x D x H)

- ✓ Width: 433 mm
- ✓ Depth: 635 mm
- ✓ Height: 786 mm

External dimensions with stand

- ✓ Width with stand: 433 mm
- ✓ Depth with stand: 638 mm
- ✓ Height with stand: 1155 mm

Net weight: 39 kg

Noise level (1m.): <70 dB(A)

Background noise: 32 dB(A)

AVAILABLE MODELS

1000670 Potato peeler-salad drier PES-20 230-400/50/3N

1000671 Potato peeler-salad drier PES-20 230/50/1

1000672 Potato peeler-salad drier PES-20 220-380/60/3N

1000673 Potato peeler-salad drier PES-20 220/60/1

1000676 Potato peeler-salad drier PES-20 120/60/1

1000995

1000996

* Ask for special versions availability

SALES DESCRIPTION

As potato peeler: 20 kg load per cycle.
As salad dryer: 2 kg load per cycle (20 kg/h) capacity.

- ✓ Potato peeler manufactured in stainless steel.
- ✓ Aluminium base plate lined with silicon carbide abrasive (approved by NSF), easily removable for cleaning purposes.
- ✓ Water inlet system with non-return air break.
- ✓ Watertight controls (IP65).
- ✓ Lifiable cover.
- ✓ As salad dryer:
- ✓ Capacity: 2 Kg per cycle (20 Kg/h).
- ✓ Volume: 19.5 litres.

INCLUDES

- ✓ Abrasive plate.
- ✓ Drying basket.

OPTIONAL

- Stainless steel floor stand.
- Knife plate.
- Filter with no-foam feature.

ACCESSORIES

- Knife plate for PES-20
- Filters for potato peelers M / PI / PES
- Stands for potato peelers
- Plastic basket set

SPECIFICATIONS

Peeler function

- ✓ Hourly production: 300 kg
- ✓ Capacity per load: 20 kg



DYNAMIC PREPARATION
COMMERCIAL POTATO PEELERS

product sheet
updated 22/07/2024



PEELER & SALAD DRYER PES-20

2 in 1: potato peeler & salad dryer.



DYNAMIC PREPARATION
COMMERCIAL POTATO PEELERS

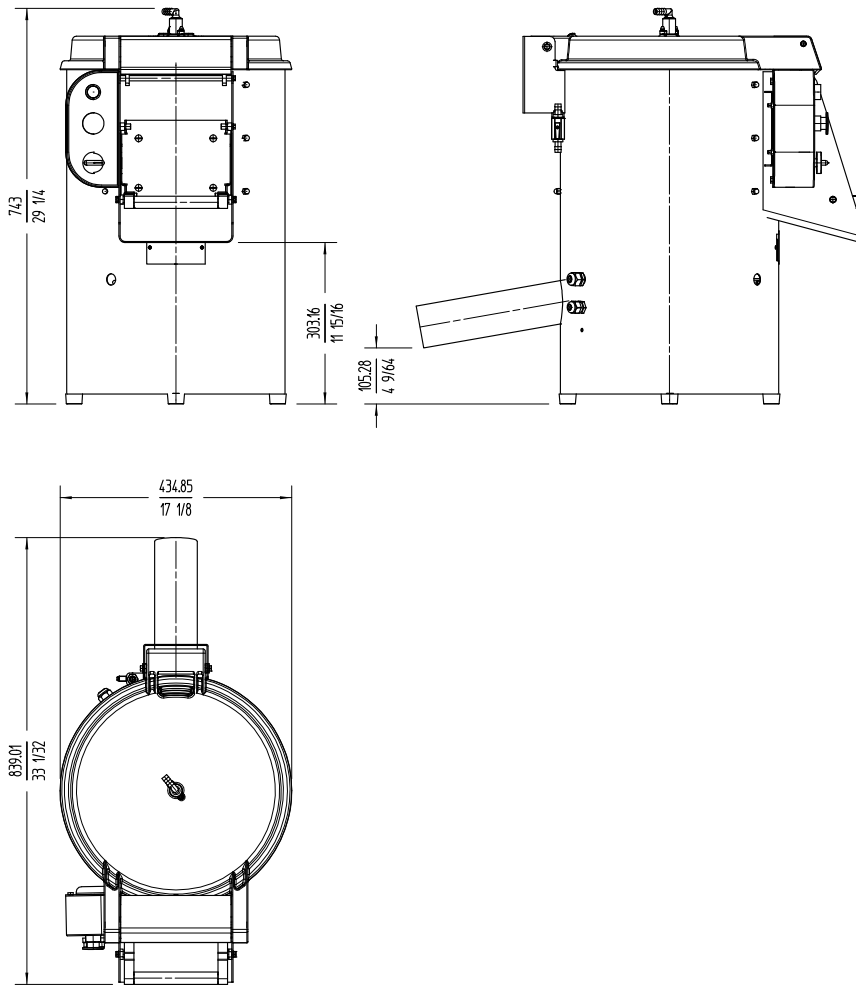

 **sammic** | www.sammic.com
Food Service Equipment Manufacturer

Polígono Basarte, 1.
20720 Azkoitia, Spain

phone +34 943 15 72 36
sales@sammic.com



Project	Date
Item	Qty
Approved	

product sheet
updated 22/07/2024