

2330 MAEHW mixer

Powerful mixer, in regards to traditional kneading
Up to 160 kg of dough*

- Robustness
- Large-scale production
- The fork tool's shape and positioning, combined with the bowl's geometry, ensure smooth and gentle kneading.



- Hydraulic head lift and bowl lock
- Variable bowl speed for greater precision

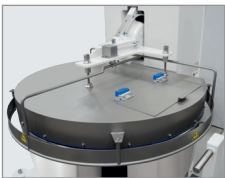

Stainless steel bowl cover with access door



For more information:



Commercial
documentation

* Maximum dough capacity. Example for an average hydration rate of 60%.

Fork mixer with removable bowl 2330 MAEHW

General Features



- Steel frame painted in white, on feet
- Stainless steel bowl
- Hydraulic bowl locking and head lifting
- Clip bowl lifting system
- Positive bowl driving system with gears and belt reduction
- Bowl speed adjustable by potentiometer
- Stainless steel bowl cover, with suspension and safety lever
- Aluminium 2 arm mixing tool
- Control panel with 3 timers and 3 potentiometers
- 400 V - 3 phases + Earth - 50Hz (any other specific voltage available and free of charge providing that it is technically possible)
- Intensity: 21 A
- IP 54



>> Specific rates and conditions apply

2330 MAEHW

Code: B50211004

Upon request



Cover with access door

Optional extra

B50203215-CI

Extra stainless steel bowl on trolley

Upon request

Capacity motorized bowl	2330 MAEHW
Total bowl volume (l)	330
Max. dough capacity (kg)*	160
Weight (kg)	1650
Motorization (kW)	
Tool motor	7
Bowl motor	1,5
Hydraulic system motor	0,4
Dimensions (mm)	
Width (A)	1205
Height closed (B)	1530
Height open (B')	1850
Depth (C)	1760

*Example for an average hydration rate of 60%.
More information here.

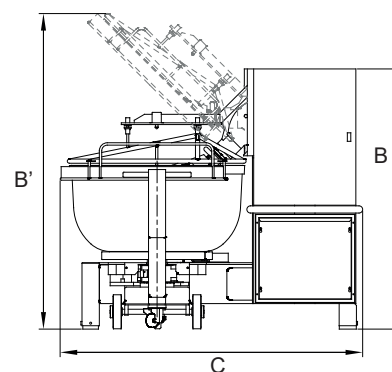
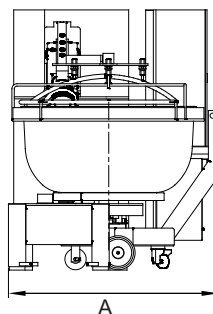

See conditions on page 5