

**Dimensions:**

853mm (w) x 890mm (p) x 875mm (h)

**Weight:** 203 kg

**Thermal Flow:** 26 kw

**Type:** A

**Category:** II<sub>2H3+</sub>

**Voltage:** 230 V

**Electric Power:** 103 w

**Butane gas**

Pressure - 28-30 mbar

Consumption - 2,1 kg/h

**Propane gas**

Pressure - 37 mbar

Consumption - 2,1 kg/h

**Natural gas**

Pressure - 20 mbar

Consumption - 2,8 m<sup>3</sup>/h

**Attention:**

*This model does not support fixed grille*

**Include spits:**

4 double + 1 suckling pig + 1 meat

**Dimensions:**

853mm (w) x 890mm (p) x 875mm (h)

**Poids:** 203 kg

**Débit thermique:** 26 kw

**Tipo:** A

**Catégorie:** II<sub>2H3+</sub>

**Tension:** 230 V

**Puissance électrique:** 103 w

**Gaz Butane**

Pression - 28-30 mbar

Consommation - 2,1 kg/h

**Gaz Propane**

Pression - 37 mbar

Consommation - 2,1 kg/h

**Gaz Naturel**

Pression - 20 mbar

Consommation - 2,8 m<sup>3</sup>/h

**Attention:**

*ce modèle ne supporte pas le gril fixe*

**Avec broches:**

4 double + 1 pour cochon de lait + 1 tournebroche

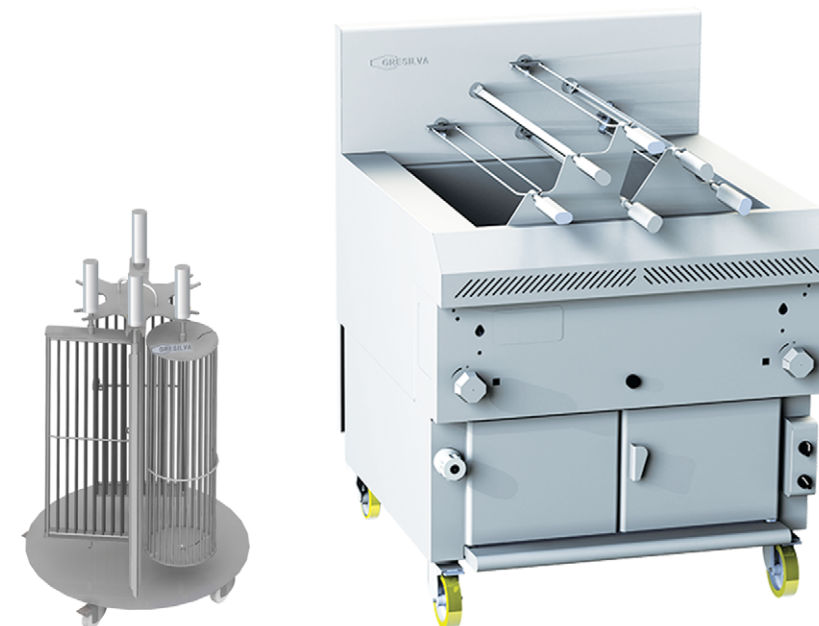

GRE.R8.S10  
Support for grids  
Support pour les grilles



GRE.R8.I10  
Double spit  
Double broche



GRE.R8.M10  
Meat spit  
Tournebroche



GRE.R8.L10  
Suckling pig spit  
Broche pour cochon de lait



GRE.R8.H10  
Rotating grid  
Grille tourné



GRE.R8.I10  
Cylindrical spit  
Grille cylindrique

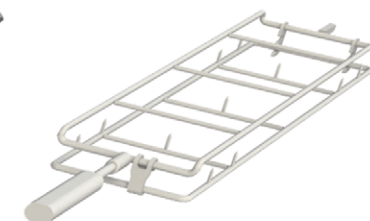

GRE.R8.I10  
Grid for rib  
Grille pour nervure



# Line | Ligne 9

Horizontal Grill | Gril Horizontal  
mod GHPI **R6/850**



[www.gresilva.com](http://www.gresilva.com)



Fixed version (height 875 mm) | Version fixe (hauteur 875 mm)

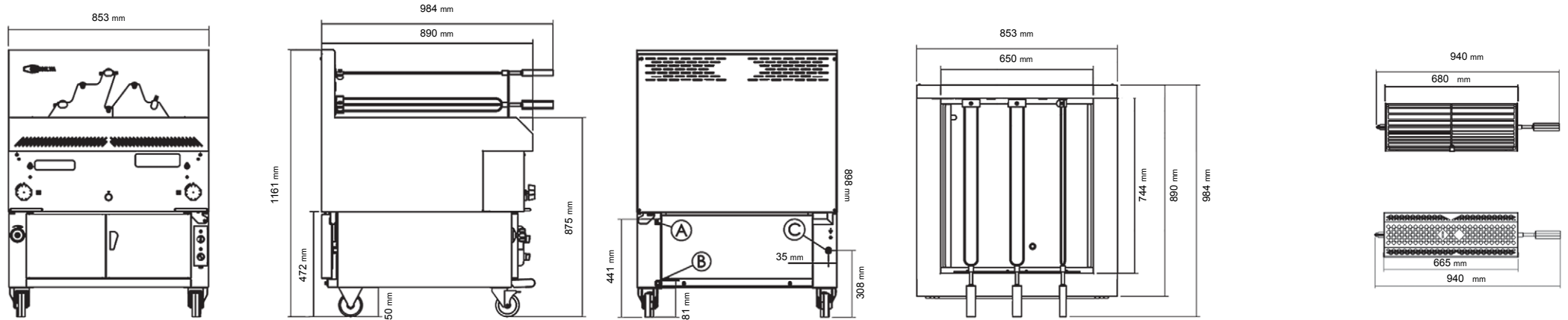

Mobile version with box for gas cylinders (height 905 mm, robust wheels for easy movement)  
Version mobile avec boîte pour bouteilles de gaz (hauteur 905 mm, roues robustes pour un déplacement facile)

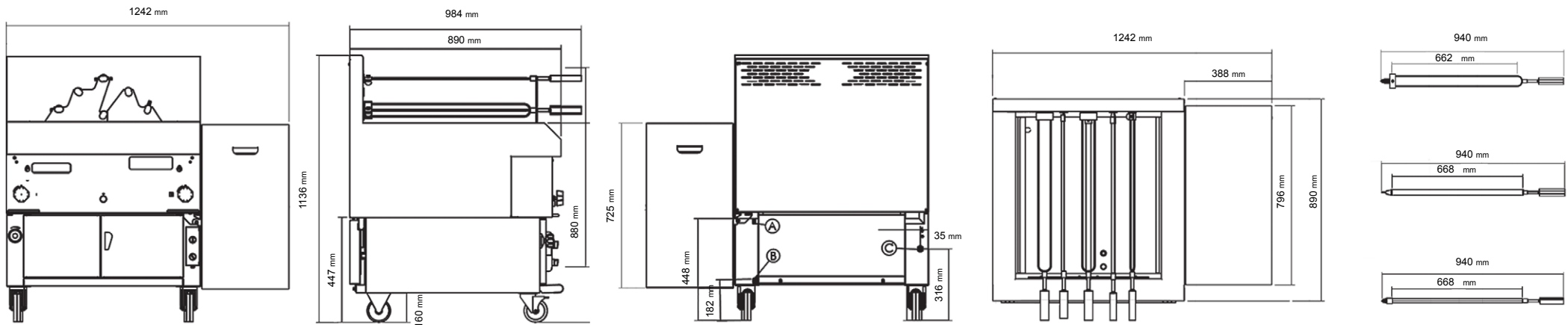

A - gas inlet 1/2" | B - power cord output | C - water inlet 3/4"  
A - Entrée de gaz 1/2" | B - Sortie du cordon d'alimentation | C - Entrée d'eau 3/4"