

Dimensions:

800 mm (w) x 900 mm (p) x 875 mm (h)

Grilling area / Zone de grillade:

622 mm x 737 mm

Weight / Poids: 165 kg

Thermal Flow / Débit thermique: 26 kw

Type: A

Category / Catégorie: II_{2H3+}

Voltage / Tension: 230 V

Electric Power / Puissance électrique: 0,6 w

Butane gas / Gaz butane

Pressure / Pression - 28-30 mbar

Consumption / Consommation - 2,1 kg/h

Propane gas / Gaz propane

Pressure / Pression - 37 mbar

Consumption / Consommation - 2,1 kg/h

Natural gas / Gaz naturel

Pressure / Pression - 20 mbar

Consumption / Consommation - 2,6 m³/h

Built in available / Disponible pour l'intégration

Horizontal Grill | Gril Horizontal
mod GHPI **2/800**



support with extra grids, high ajustable
support avec grilles extra, réglable en hauteur



with water inlet and outlet
avec arrivée et sortie d'eau



scraper
grattoir

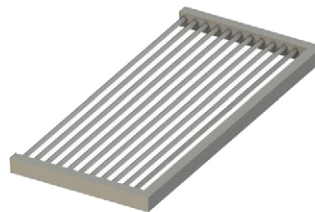

grid
grill

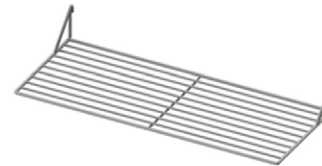

extra grid
extra grill



support grids
porte-grille



pack



Line | Ligne 9

Horizontal Grill | Gril Horizontal
mod GHPI 2/800



www.gresilva.com

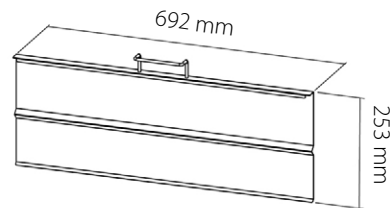
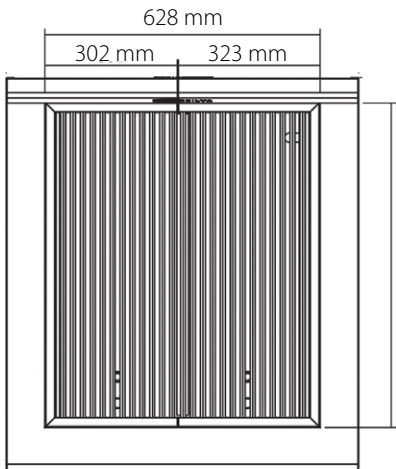
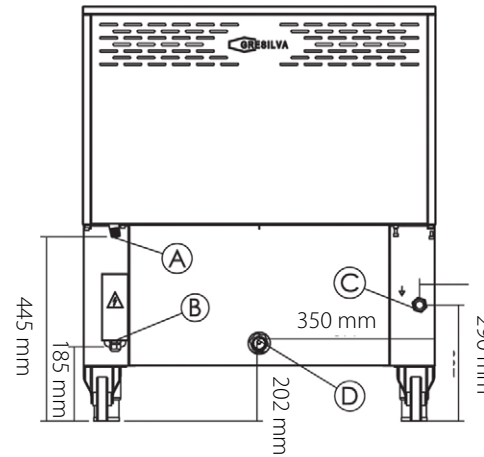
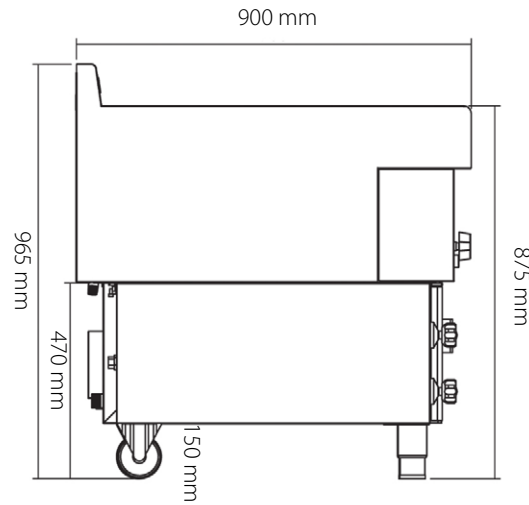
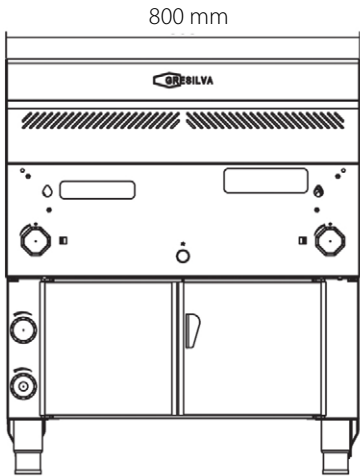

protective plate for ceramic tiles
plaque de protection pour carreaux de céramique

- A - gas inlet 1/2"
- A - entrée de gaz 1/2"
- B - power cord output
- B - sortie du cordon d'alimentacion
- C - water inlet 3/4"
- C - arrivée d'eau 3/4"
- D - wastewater outlet 1"
- D - sortie des eau usées 1"

