



## IRIS ARB - ARS



ITA **IMPASTATRICE A SPIRALE ROVESCIBILE**

*Impastatrici a spirale rovesciabili* di robusta costruzione e dalle ottime prestazioni, solidamente incorporate in un sistema di sollevamento a funzione idraulica. Ideale e versatile per risolvere semplici problemi di automazione.

Disponibili anche con motore potenziato per impasti particolarmente tenaci, con scarico sul lato destro o sinistro, su tavolo (ARB) o tramoggia di spezzatrice volumetrica (ARS).

---

ENG **OVERTURNABLE SPIRAL MIXER**

Overtunable spiral mixers of robust construction with excellent performances. Firmly incorporated with a hydraulic lifting system, this mixer is very flexible and ideal to solve simple automation. It is available with reinforced drive spiral motor, for tough dough, and right or left tilting side on working bench (ARB) or on of volumetric divider hopper (ARS).

---

FRA **PÉTRIN À SPIRALE CUVE RENVERSABLE**

Pétrins à spirale avec cuve renversible de forte construction et d'excellentes performances bien incorporées dans un système de soulèvement hydraulique.

Idéals et universels pour régler les plus simples problèmes d'automatisation.

Disponibles aussi avec moteur renforcé pour

mélanges assez durs avec renversement à droite ou à gauche sur table (ARB) et trémie d'une diviseuse volumétrique (ARS).

---

ESP **AMASADORA DE ESPIRAL DE VOLQUETE**

Amasadoras de espiral de volquete de sólida construcción, con prestaciones excepcionles, montadas solidamente en un sistema de levantamiento hidráulico. Ideal y versátil para resolver los problemas específicos de automatización.

Disponible con motor reforzado, para amasijos tenaces, y con descarga en lado derecho o izquierdo sobre mesa (ARB) ó bien sobre tolva de una divisora volumétrica (ARS).

---

DEU **AUSKIPPENDER SPIRAL - KNETER**

Auskippender Spiral-Kneter von robuster Bauweise mit sehr guten Leistungen. Fester Kessel, und einem hydraulischen Hebe-System, das Bedienpult ist sehr flexibel und ideal für eine einfache Automatisierung.

Sie ist in verstärkter Ausführung für sehr harte Teige, sowie nach rechts oder links kippend, auf Tischhöhe (ARB) oder Trichterhöhe einer Teilmaschine (ARS) erhältlich.



**LOGIUDICE**  
PART OF TP FOOD GROUP



MADE IN ITALY

## IRIS - ARB

Modello Model Modèle Modelo	Impasto Dough Pâte Masa		Farina Flour Farine Harina		Vasca Bowl Cuve Cuba	Dimensioni Dimensions Dimensions Dimensiones						Peso Weight Poids Peso	Potenza Power Puissance Potencia
	Kg min	Kg max	Kg min	Kg max		A cm	B cm	C cm	H1 cm	H2 cm	H3 cm		
<b>ARB - ARS</b>					<b>Lt.</b>							<b>Kg</b>	<b>Kw</b>

### IRIS ARB

<b>ARB-100</b>	8	100	5	65	145	174	165	160	144	158	244	1190	5.7
<b>ARB-130</b>	12	130	6	80	193	174	165	167	139	153	259	1360	6.9
<b>ARB-160</b>	15	160	6	100	250	180	165	177	138	152	275	1520	8.5
<b>ARB-200</b>	17	200	6	125	275	180	165	177	137	151	274	1520	8.5
<b>ARB-250</b>	22	250	9	150	320	187	165	175	133	147	277	1570	9.7
<b>ARB-300</b>	27	300	12	180	420	191	165	180	127	141	287	1620	12.5

### IRIS ARB - D

<b>ARB-100-D</b>	8	100	5	65	145	174	165	160	144	158	244	1190	6.9
<b>ARB-130-D</b>	12	130	6	80	193	174	165	167	139	153	259	1360	10.2
<b>ARB-160-D</b>	15	160	6	100	250	180	165	177	138	152	275	1520	12.5
<b>ARB-200-D</b>	17	200	6	125	275	180	165	177	137	151	274	1520	12.5
<b>ARB-250-D</b>	22	250	9	150	320	187	165	175	133	147	277	1570	17.2
<b>ARB-300-D</b>	27	300	12	180	420	191	165	180	127	141	287	1620	17.2

#### NOTE

Inferiore al 55 % d'acqua si consiglia la macchina con motore rinforzato. ARB/ARS- D

For water content lower than 55%, we recommend the reinforced motor version of spiral mixer. ARB/ARS- D

Pour pâtes avec une pourcentage d'eau inférieur à 55% on conseil la version avec moteurs poussée. ARB/ARS- D

Amasijo con un porcentaje de hidratación inferior al 55% se recomienda la versión con motor reforzado. ARB/ARS- D



Voltaggio standard 400V/3Ph/50Hz - Voltaggio diversi, MONOFASE o TRIFASE disponibili su richiesta  
 Standard voltage 400V/3Ph/50Hz.. - Different voltages, SINGLE PHASE or THREE PHASE available on request  
 Tension standard 400V/3Ph/50Hz - Différentes tensions, MONOPHASÉ ou TRIPHASÉ disponibles sur demande  
 Tensión estándar 400V/3Ph/50Hz - Diferentes voltajes, MONOFÁSICO o TRIFÁSICO disponibles bajo pedido

**ARB**  
 Altezza minima soffitto: 2.85 mt  
 Minimum ceiling height: 2.85 mt  
 Hauteur minimum du plafond: 2.85 mt  
 Altura mínima del techo: 2.85 mt

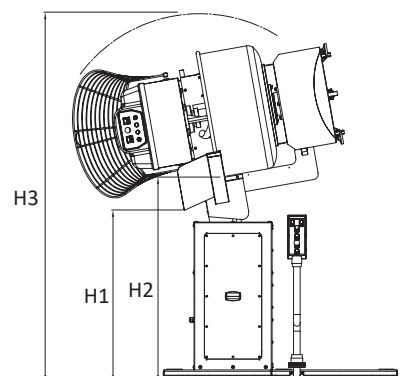
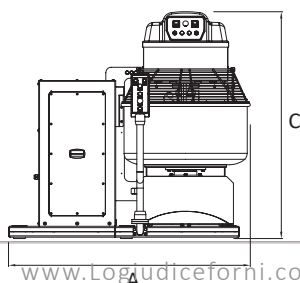
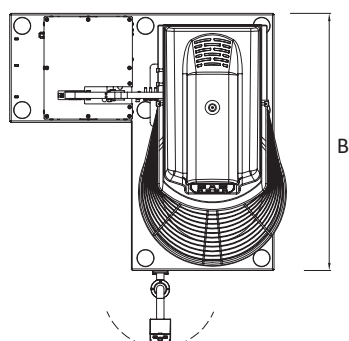

## IRIS - ARS

Modello Model Modèle Modelo	Impasto Dough Pâte Masa		Farina Flour Farine Harina		Vasca Bowl Cuve Cuba	Dimensioni Dimensions Dimensions Dimensiones						Peso Weight Poids Peso	Potenza Power Puissance Potencia
	Kg min	Kg max	Kg min	Kg max		A cm	B cm	C cm	H1 cm	H2 cm	H3 cm		
ARB - ARS					Lt.							Kg	Kw

### IRIS ARS

<b>ARS-100</b>	8	100	5	65	145	174	165	160	175	189	275	1300	5.7
<b>ARS-130</b>	12	130	6	80	193	174	165	167	170	184	290	1470	6.9
<b>ARS-160</b>	15	160	6	100	250	180	165	177	169	183	306	1630	8.5
<b>ARS-200</b>	17	200	6	125	275	180	165	177	168	182	305	1630	8.5
<b>ARS-250</b>	22	250	9	150	320	187	165	175	164	178	308	1680	9.7
<b>ARS-300</b>	27	300	12	180	420	191	165	180	158	172	318	1730	12.5

### IRIS ARS - D

<b>ARS-100-D</b>	8	100	5	65	145	174	165	160	175	189	275	1300	6.9
<b>ARS-130-D</b>	12	130	6	80	193	174	165	167	170	184	290	1470	10.2
<b>ARS-160-D</b>	15	160	6	100	250	180	165	177	169	183	306	1630	12.5
<b>ARS-200-D</b>	17	200	6	125	275	180	165	177	168	182	305	1630	12.5
<b>ARS-250-D</b>	22	250	9	150	320	187	165	175	164	178	308	1680	17.2
<b>ARS-300-D</b>	27	300	12	180	420	191	165	180	158	172	318	1730	17.2

#### NOTE

Inferiore al 55 % d'acqua si consiglia la macchina con motore rinforzato. ARB/ARS- D

For water content lower than 55%, we recommend the reinforced motor version of spiral mixer. ARB/ARS- D

Pour pâtes avec une pourcentage d'eau inférieur à 55% on conseil la version avec moteurs poussée. ARB/ARS- D

Amasijo con un porcentaje de hidratación inferior al 55% se recomienda la versión con motor reforzado. ARB/ARS- D



Voltaggio standard 400V/3Ph/50Hz - Voltaggio diversi, MONOFASE o TRIFASE disponibili su richiesta  
Standard voltage 400V/3Ph/50Hz.. - Different voltages, SINGLE PHASE or THREE PHASE available on request  
Tension standard 400V/3Ph/50Hz - Différentes tensions, MONOPHASE ou TRIPHASE disponibles sur demande  
Tensión estándar 400V/3Ph/50Hz - Diferentes voltajes, MONOFÁSICO o TRIFÁSICO disponibles bajo pedido

**ARS**  
Altezza minima soffitto: 3.20 mt  
Minimum ceiling height: 3.20 mt  
Hauteur minimum du plafond: 3.20 mt  
Altura mínima del techo: 3.20 mt

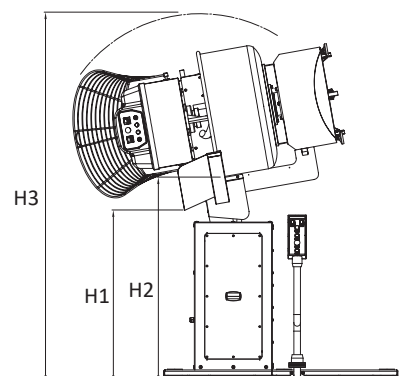
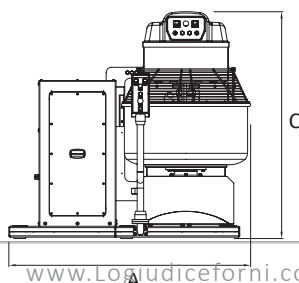
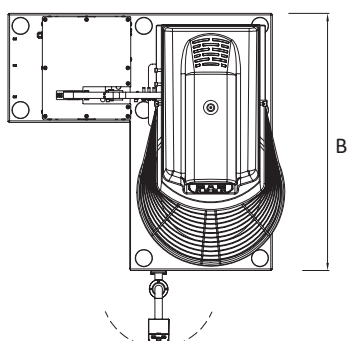

## Optionals

Pannello LCD 4.3"  
LCD 4.3" control panel  
Tableau LCD 4.3"  
Panel LCD 4.3"



Pannello comando touch screen 7" + inverter  
Touch screen control panel 7" + inverter  
Tableau avec écran tactile 7" + Variateur de vitesse  
Panel touch screen 7" + inverter



Supplemento ULCSA  
Extra cost for UL-CSA  
Supplément ULCSA  
Suplemento ULCSA

Sonda rilevamento temperatura solo con pannello touch screen e LCD  
Temperature probe only with touch screen control panel and LCD  
Sonde température uniquement avec panneau de commande à écran tactile et LCD  
Sonda relevación temperatura solo con el panel de control touch screen y LCD

Sonda rilevamento temperatura con termoregolatore  
Temperature probe with thermostat  
Sonde température avec thermostat  
Sonda relevación temperatura con termoregulador

Carpenteria in acciaio inox  
Stainless steel body  
Charpente en acier inox  
Estructura en acero inoxidable

Raschiatore.  
Bowl scraper.  
Racleur.  
Rascador artesa.

Scarico a destra.  
Right hand tipping.  
Renversement à droite.  
Descarga de la masa en el lado derecho.

Scivolo scarico pasta in acciaio inox.  
Dough chute in stainless steel.  
Glissière déchargement de la pate en acier inox.  
Rampa acompañamiento masa en acero inox.

Kit contaltri: dosatore d'acqua incorporato all'impastatrice (solo pannello touch screen e LCD)  
Kit water meter: water meter integrated with the mixer (only with touch screen control panel and LCD)  
Kit compteur d'eau: doseur d'eau incorporé au pétrin (uniquement avec panneau de commande à écran tactile et LCD)  
Kit cuenta litros: Kit cuenta litros incorporado a la amasadora (solo con el panel de control touch screen y LCD)

**NOTE**



# LOGIUDICE

PART OF TP FOOD GROUP

Logiudice Forni srl unipersonale  
Via Macia, 14  
37040 Arcole - Verona  
Italy

Tel. +39 045 618 01 26  
Tel. +39 045 763 61 50

Fax +39 045 763 66 05

[info@logiudiceforni.com](mailto:info@logiudiceforni.com)  
[www.logiudiceforni.com](http://www.logiudiceforni.com)



L'azienda si riserva il diritto di apportare eventuali modifiche nell'ottica di un continuo miglioramento dei propri prodotti. | The Manufacture reserves the right to make any change to the product with the purpose of improving its quality. | La société se réserve le droit d'apporter toutes modifications dans le but d'améliorer sa propre gamme de produits. | La empresa se reserva el derecho de aportar cualquier modificación en la óptica de una continua mejora de sus productos.