



**LOGIUDICE**  
PART OF TP FOOD GROUP

**LOGIUDICE**

*The Gentle Art of Mixing for a Better Bakery Experience*

# IRIS



Impastatrici a spirale  
a vasca fissa

Fixed bowl spiral  
mixers

Pétrins à spirale  
avec cuve fixe



S

—

R

—





IT

La buona riuscita dell'impasto è garantita dall'ottimo rapporto di velocità utensile spirale e giro vasca. In questo modo si riducono i tempi di lavoro e si conferisce omogeneità, ossigenazione e raffinazione all'impasto, mantenendo costante la temperatura.

EN

A successful mixing is ensured by the optimal ratio between the spiral tool speed and the bowl revolution. This reduces the working time and gives homogeneity, oxygenation and refinement to the dough, while maintaining a constant temperature.

FR

La réussite du mélange est assurée par le rapport optimal entre la vitesse de l'outil à spirale et la révolution de la cuve. Cela réduit le temps de travail et donne de l'homogénéité, de l'oxygénation et de l'affinage à la pâte, tout en maintenant une température constante.



**CARATTERISTICHE TECNICHE**  
**TECHNICAL FEATURES**  
**CARACTÉRISTIQUES TECHNIQUES**  
**CARACTERÍSTICAS TÉCNICAS**



**IT**

1. Nuove trasmissioni a cinghie trapezoidalicon puleggia doppio rinvio sia per l'utensile spirale che per la vasca
2. Due motori a doppia velocità (motore singolo per IRIS-030/040)
3. Struttura in acciaio verniciato di grosso spessore montata su ruote con piedini di appoggio
4. Pannello comandi: ELETTRMECCANICO (A), DIGITALE (B), TOUCH SCREEN (C) o TOUCH SCREEN 4.0 (D)
5. Protezione vasca in ABS chiusa o con griglia in acciaio inossidabile

**EN**

1. New double pulley belt transmission both for spiral tool and bowl
2. 2 motors with 2 speeds (single motor for IRIS-030/040)
3. Thick coloured steel frame mounted on weels with ad justable feet
4. Control panel: ELECTROMECHANICAL (A), DIGITAL (B), TOUCH SCREEN (C) or TOUCH 4.0 (D)
5. ABS bowl safety guard (closed type) or stainless steel grid

**FR**

1. Nouvelle transmission par courroies trapézoïdales avec double poulie de renvoi
2. Deux moteurs à double vitesse avec (moteur unique pour IRIS-030/040)
3. Structure en acier verni de gros épaisseur montée sur roulettes avec pieds réglables
4. Tableau de commandes: ELECTROMECHANIQUE (A), DIGITAL (B), ECRAN TACTILE (C) ou TACTILE 4.0 (D)
5. Protection de la cuve en ABS ou avec grille en acier inoxydable

**ES**

1. Nuevas transmisiones de poleas dobles para espiral y artesa
2. Dos motores de doble velocidad (motor individual para IRIS-030/040)
3. Estructura en acero barnizado de grueso espesor y montada sobre ruedas con pies regulables
4. Panel de mandos: ELECTROMECHANICO (A), DIGITAL (B), TACTIL (C) o TACTIL 4.0 (D)
5. Protección artesa en ABS (cerrada) o con parilla en acero inoxidable





**IMPASTI UNICI DALL'INCONFONDIBILE TOCCO ITALIANO PER CREAZIONI D'ECCELLENZA**  
**A GENTLE MIXING WITH THE UNMISTAKABLE ITALIAN TOUCH FOR EXCELLENT CREATIONS**  
**DES MELANGE FORMIDABLES POUR DES CREATIONS D'EXCELLENCE AVEC UNE TOUCHE ITALIENNE**  
**MASAS SUAVES CON EL INCONFUNDIBLE TOQUE ITALIANO PARA EXCELENTES CREACIONES**

**IT**

Realizzata utilizzando le più moderne tecnologie costruttive l'impastatrice IRIS racchiude in un'unica macchina l'**esperienza**, la **sicurezza** nel lavoro, il **design** e la **semplicità** d'utilizzo. La linea di impastatrici a spirale a vasca fissa è disponibile con **capacità da 30 a 300 kg di impasto**. La macchina monta motori a due velocità sia per l'utensile spirale che per la vasca ed è disponibile la versione con motori potenziati per **impasti tenaci**. IRIS è ideale anche per **impasti ad alta idratazione**.

**FR**

Abriqué à l'aide des technologies de construction les plus récentes, le pétrin IRIS rassemble **expérience**, **sécurité** de fonctionnement, **design** et **facilité** d'utilisation dans une seule machine. La gamme de pétrins à spirale avec cuve fixe est disponible avec **une capacité de 30 à 300 kg de pâte**. La machine est équipée de moteurs à deux vitesses pour l'outil à spirale et la cuve, et une version avec des moteurs renforcés pour les **pâtes dures** est disponible. IRIS est également idéal pour les **pâtes à forte hydratation**.

**EN**

Made using the latest construction technologies the IRIS mixer machine brings together **experience**, **safety**, **design** and **ease** of use in a single machine. The line of fixed-bowl spiral mixers is available with **capacities from 30 to 300 kg dough**. The machine mounts two-speed motors for both the spiral tool and the bowl, and an enhanced motor version is available for **tough doughs**. IRIS is also ideal for **high-hydration doughs**.

**ES**

Fabricada con las últimas tecnologías de construcción, la amasadora IRIS combina **experiencia**, **seguridad**, **diseño elegante** y **facilidad** de uso en una sola máquina. La línea de amasadoras de espiral con artesa fija está disponible con una **capacidad de 30 a 300 kg de masa**. La máquina está equipada con motores de dos velocidades tanto para la espiral como para la cuba, y hay disponible una versión con motores reforzados para **masas duras**. IRIS también es ideal para **masas de alta hidratación**.



**PANNELLO COMANDI CERTIFICATO PER L'INDUSTRIA 4.0 | CONTROL PANEL CERTIFIED FOR INDUSTRY 4.0 | TABLEAU DES COMMANDES CERTIFIÉ POUR L'INDUSTRIE 4.0 | PANEL DE MANDOS CERTIFICADO PARA INDUSTRIA 4.0**



**A**



**B**



**C**



**D**

# IRIS



**IT** Impasti unici dall'inconfondibile tocco italiano adatti sia per impasti ad alta idratazione che impasti tenaci.

**EN** A gentle mixing with the unmistakable Italian touch both for low and high hydration dough.

**FR** Un pétrissage parfait avec une touche italienne aussi pour pâtes haute hydratation que pour pâtes dures.

**ES** Amasadoras suaves con un inconfundible toque italiano para tanto en caso de masas muy hidratada que de masas dura.

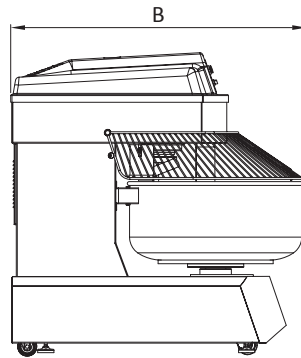
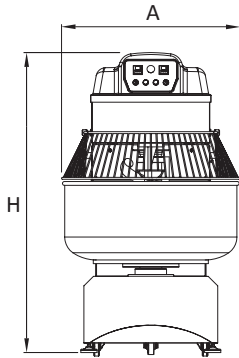

Voltaggio standard  
400V/3Ph/50Hz \*

Standard voltage  
400V/3Ph/50Hz \*

Tension standard  
400V/3Ph/50Hz \*

Tensión estándar  
400V/3Ph/50Hz \*

## IRIS

Modello Model Modèle Modelo	Impasto Dough Pâte Masa		Farina Flour Farine Harina	Vasca Bowl Cuve Artesa	Dimensioni Dimensions Dimensions Dimensiones			Potenza Power Puissance Potencia		
	Kg min	Kg max	Kg	Lt.	A cm	B cm	H cm	Kw		
<b>IRIS-030</b>	2	30	20	54	57	89	119	1.9		
<b>IRIS-040</b>	4	40	27	63	57	89	119	1.9		
<b>IRIS-060</b>	5	60	36	95	64	101	139	3.8		
<b>IRIS-080</b>	<b>IRIS-080-D</b>	6	80	50	127	75	119	145	4.6	5.7
<b>IRIS-100</b>	<b>IRIS-100-D</b>	8	100	65	145	75	119	145	5.7	6.5
<b>IRIS-130</b>	<b>IRIS-130-D</b>	12	130	80	193	85	140	150	6.9	9.5
<b>IRIS-160</b>	<b>IRIS-160-D</b>	15	160	100	250	95	156	160	8.5	12.5
<b>IRIS-200</b>	<b>IRIS-200-D</b>	17	200	125	275	95	156	160	8.5	12.5
<b>IRIS-250</b>	<b>IRIS-250-D</b>	22	250	150	320	105	163	160	9.7	17.2
<b>IRIS-300</b>	<b>IRIS-300-D</b>	27	300	180	420	113	173	166	12.5	17.2

Voltaggio diversi, MONOFASE o TRIFASE disponibili su richiesta | Different voltages, SINGLE PHASE or THREE PHASE available on request | Diferentes voltajes, MONOFÁSICO o TRIFÁSICO disponibles bajo pedido | Différentes tensions, MONOPHASÉ ou TRIPHASÉ disponibles sur demande

**OPZIONI | OPTIONAL  
OPTIONS | OPCIONES**



**E**

**IT**

- Sonda rilevamento temperatura (E)
- Raschiatore
- Contalitri: dosatore d'acqua incorporato (solo pannello digitale o touch screen)
- Trasmissione spirale rinforzata per impasti duri (160, 200, 250, 300)
- Protezione vasca in ABS trasparente

**EN**

- Temperature probe (E)
- Bowl scraper
- Liter-counter: water meter integrated (available with digital or touch screen control panel only)
- Reinforced spiral transmission for very hard dough (160, 200, 250, 300)
- Transparent ABS bowl protection

**FR**

- Sonde température (E)
- Racléur de cuve
- Compteur d'eau: doseur d'eau incorporé (uniquement avec tableau digital ou écran tactile)
- Transmission spiral renforcée pour pâte très dure (160, 200, 250, 300)
- Protection de la cuve en ABS transparent

**ES**

- Sonda relevación temperatura (E)
- Rascador artesa
- Cuenta litros: kit cuenta litros incorporado (solo con panel digital o táctil)
- Transmisión espiral reforzada para masas duras (160, 200, 250, 300)
- Protección artesa en ABS transparente

**Scoprite tutti i prodotti  
LOGIUDICE!**

**Discover all our LOGIUDICE  
products ranges!**

**Découvrez tous nos  
produits LOGIUDICE!**

**Descubren todos nuestros  
productos LOGIUDICE!**

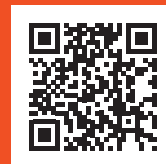

L'azienda si riserva il diritto di apportare eventuali modifiche nell'ottica di un continuo miglioramento dei propri prodotti.

The Manufacture reserves the right to make any change to the product with the purpose of improving its quality.

La société se réserve le droit d'apporter toutes modifications dans le but d'améliorer sa propre gamme de produits.

La empresa se reserva el derecho de aportar cualquier modificación en la óptica de una continua mejora de sus productos.



IRIS ARB - ARS



GEMMA



MASTER CLASSIC



MASTER PLUS



TITANIO



Logiudice Forni srl unipersonale  
Via Macia, 14  
37040 Arcole (VR) - Italy  
Tel. +39 045 618 01 26  
Fax +39 045 763 66 05  
info@logiudiceforni.com  
[www.logiudiceforni.com](http://www.logiudiceforni.com)

