

WASHING SOLUTION - PROEasyLine SERIES

PROFESSIONAL WASHERS FROM 6 AND 8 KG

Compact design
New programming display, new UX. Suitable for built-in and stackable with dryer.

TOP performance, spin 1400 rpm.
Disinfection programs at 90°, 60° and 40° and MOP programs for cleaning companies.

AISI 304 stainless steel casing
Drum, front and top panel made of stainless steel.



Laundry weighing system
Automatic recognition of the laundry weight.

External control unit
Control card for the management of the dosing and payment system.

Unbalance control
Anti-balancing 3D sensor and "ACTIVE DRUM™" system.



SCAN FOR MORE INFO



SCAN FOR MORE INFO

OPTIONS and ACCESSORIES

- Kit 3 peristaltic automatic dosing pumps with programmable washing formulas
- Crankcase h 300 mm
- Mechanical or electronical coin box for self-service use



TECHNICAL DATA

PELW 65 ^{EDV}
EDP

PELW 80 ^{EDV}
EDP

- Capacity 1:9 - 1:10	6,7 - 6 Kg (15 - 13 lb)	8,9 - 8 Kg (20 - 18 lb)
- Drum volume	60 lt	80 lt
- Drum diameter Ø	480 mm (18.9 inch.)	480 mm (18.9 inch.)
- Load diameter Ø	310 mm (12.2 inch.)	310 mm (12.2 inch.)
- Spin speed	1400 r.p.m.	1400 r.p.m.
- G Factor	524	524
- Airborne acoustical noise emission class (a)	A++	A++
- Sound pressure and sound power	< 70 dB < 74 dB	< 70 dB < 74 dB
- Machine dimension WxDxH (100 mm = 3.93 inch.)	595x591x850 mm	595x706x850 mm
- Net weight	76,5 - 77 Kg (167.5 lb)	92 - 92,5 Kg (203 lb)
- Packing dimension WxDxH (100 mm = 3.93 inch.)	640x661x920 mm	640x776x920 mm
- Gross weight	79,7 - 80,2 Kg (172 lb)	95,4 - 95,9 Kg (207 lb)
- Packaging volume	0,40 mc (13.7 ft³)	0,46 mc (16.2 ft³)
- After spin residual humidity %	49 %	49 %
- Installation electric power	3,2 kW	4,6 kW
- 1ph230V 50 Hz / 3ph400V + N 50 Hz / 3ph 230V + 50 Hz	16 A / 10 A	16 A / 10 A
- Supply cable length	210 cm (82.7 inch.)	180 - 210 cm (71 inch.)
- Water connexion	2 x 3/4 "	2 x 3/4 "
- Inlet tube length	1500 mm (59 inch.)	1500 mm (59 inch.)
- Drain tube length	1600 mm (63 inch.)	1600 mm (63 inch.)
- Diameter tube length Ø	20 mm (0,80 inch.)	20 mm (0,80 inch.)
- STD. packed machines in to 20' container	54 pz. sovrapposte	54 pz. stackable
- STD. packed machines in to 40' container	108 pz. sovrapposte	108 pz. stackable

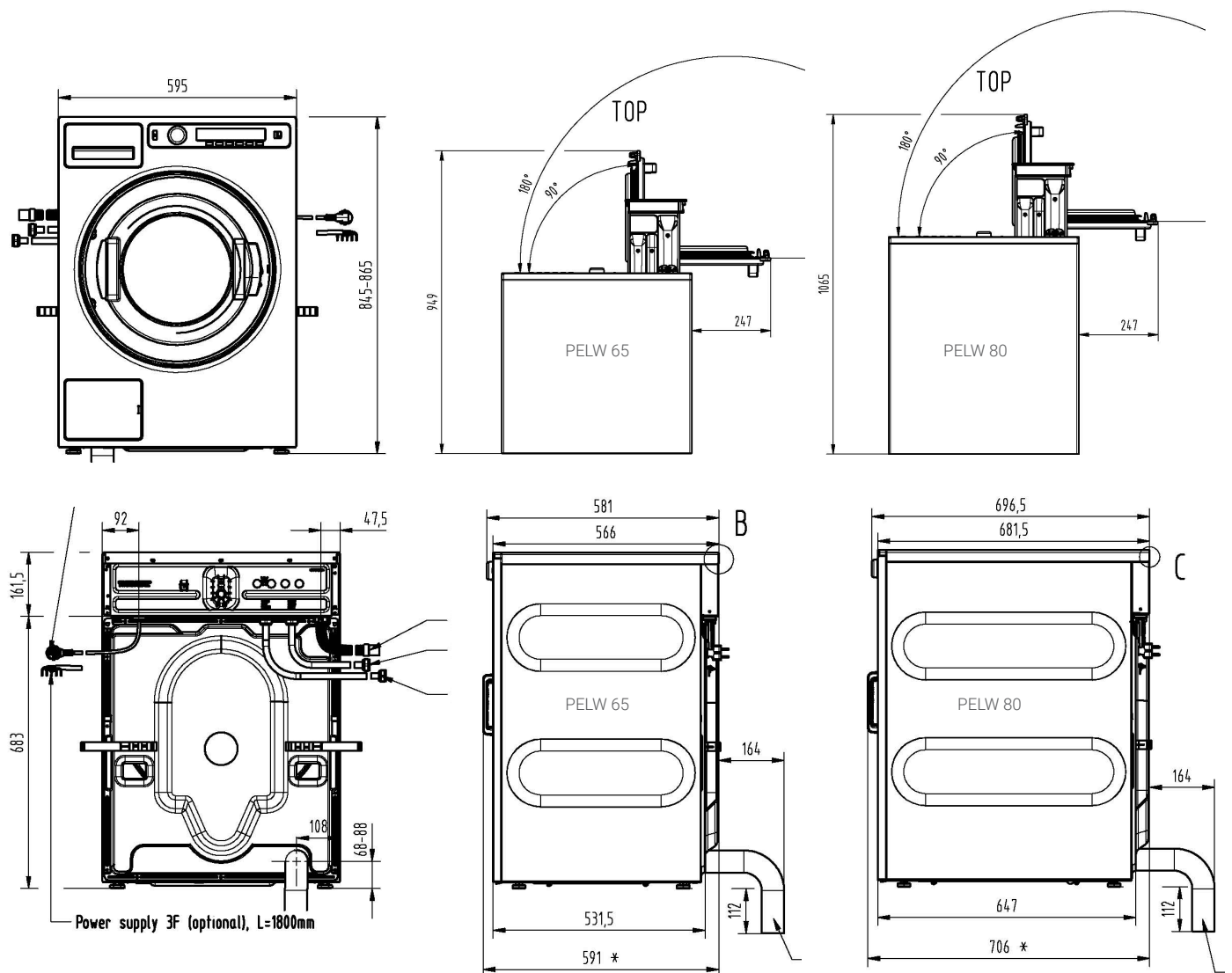

100 mm = 3.93 inch. - factor conversion 1 / 25,4

C150601X - Specification and technical data are subject to modification.

DRYING SOLUTION - PROEasyLine SERIES

PROFESSIONAL DRYERS FROM 6 AND 8 KG

Compact design
New programming display, new UX.
Suitable for built-in and stackable
with washing machine.

New door filter on more larger door
New loading door complete with
large filter.

AISI 304 stainless steel casing
Drum, front and top panel made
of stainless steel.



Energy saving
Available with heat pump for
installation in closed room.

Delicacy in drying
BUTTERFLY drying system
protects fabrics.

Reliability
Robust brushless industrial motor
for noise reduction, two additional
supporting rolls for better stability.



SCAN FOR MORE INFO

OPTIONS and ACCESSORIES

- Crankcase h 300 mm
- Mechanical or electronical coin box for self-service use



TECHNICAL DATA

PELD 65^C
EE

PELD 80^{EE}
HP

- Capacity 1:18 - 1:20	6,5 - 6 Kg (14 - 12 lb)	8,1 - 7,3 Kg (19 - 16 lb)
- Drum volume	117 lt	145 lt
- Air sound intensity	65 - 66 dB (A)	65 dB (A)
- Vent air/smokes Ø (if foreseen)	100 mm (3.9 inch.)	100 mm (3.9 inch.)
- Machine dimensions WxDxH (100 mm = 3.93 inch.) C - EE - HP	595x654x850 mm	595x769x850 mm
- Net weight C - EE	43 - 37,4 Kg (95-82 lb)	43 Kg (95 lb)
- Net weight HP	45 Kg (99 lb)	58 Kg (128 lb)
- Packing dimension WxDxH (100 mm = 3.93 inch.)	640x723x920 mm	640x838x920 mm
- Gross weight	47 - 41,8 Kg (104-93lb)	47 - 62 Kg (106-137 lb)
- Packaging volume	0,43 mc (15.2 ft ³)	0,49 mc (16.9 ft ³)
- Installation electric power C - EE	2,8 - 3,3 kW	3,3 kW
- Installation electric power HP	-	1 kW
- 1ph230V 50 Hz / 3ph400V + N 50 Hz	16 A / 10 A	16 A / 10 A
- Supply cable length	2300 mm (90.6 inch.)	2100 mm (82.7 inch.)
- STD. packed machines in to 20' container	54 pz. sovrapposte	50 pz. stackable
- STD. packed machines in to 40' container	108 pz. sovrapposte	104 pz. stackable

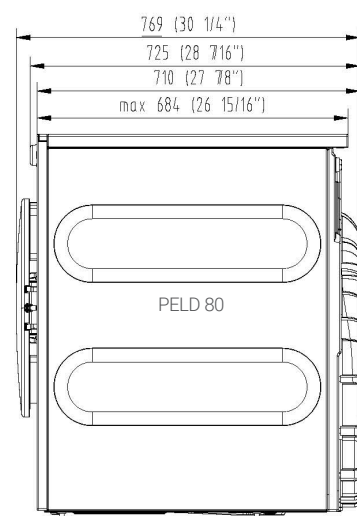
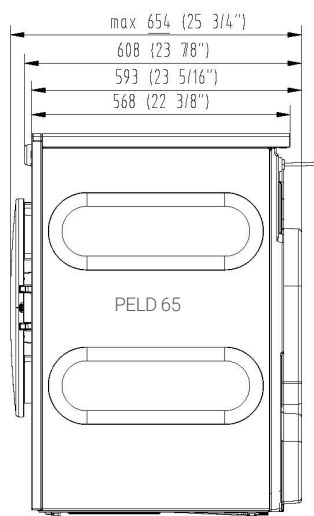
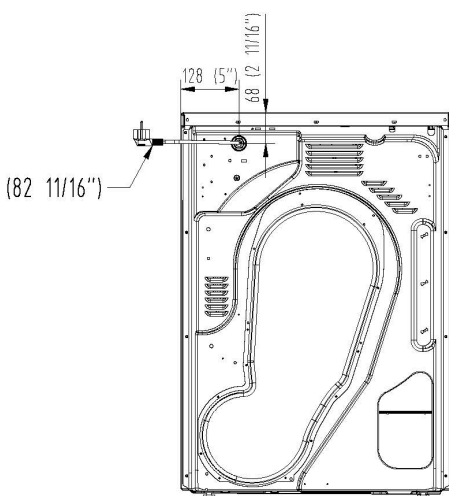
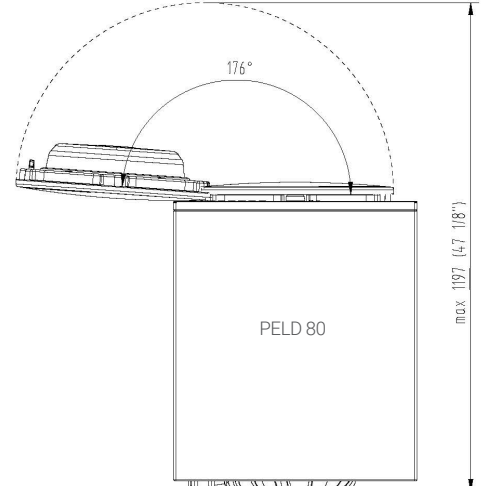
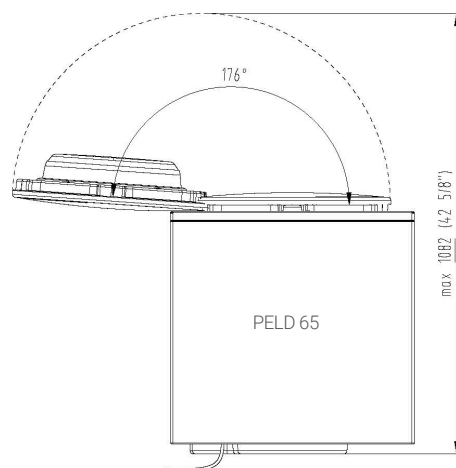
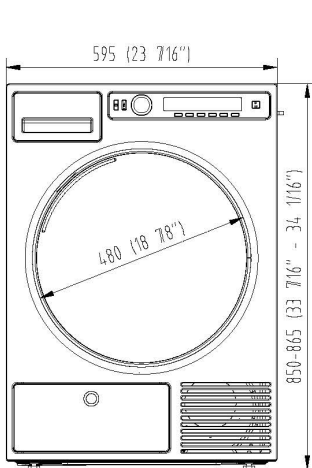

100 mm = 3.93 inch. - factor conversion 1 / 25,4

C150601X - Specification and technical data are subject to modification.