

NIECO MV74

Electric

The Broiler Built by Over 50 Years of Experience

In 1969, Nieco® began developing custom solutions to the most common challenges in restaurant kitchens when we installed our first automatic flame broiler in Tomorrowland at Disneyland®. Nieco innovations include automatic broiling that cooks twice as fast, equipment that uses less energy, keeps your kitchen cooler, and reduces emissions, keeping your kitchen cleaner too.

We are proud to introduce the next generation of Nieco's automatic flame broilers for our customers.

FEATURES

- Nieco BroilVection® technology for faster cook times, quicker service and signature flame-broiled flavor
- High-capacity, fast-heating cooking chambers provide more powerful, consistent production of fresh or frozen product than any other commercial electric broiler
- Dual 13" belts with 2 lanes each — flexible, independent cooking on either belt, choice of feeder options
- Offered in a variety of flow and feeder configurations
- Improved heat-balance for fast, reliable cook-times; grease-management system controls flaming
- Incendalyst® decreases cooking emissions by 85-90%
- Touch Screen Controller for easy operation of both chambers, programmable recipes and on-screen cleaning guide, and future-ready, IoT capability
- Next-generation BroilVection™ system simplifies daily cleaning requirement making it simple to maintain optimal performance and consistent product quality.

HEAT OPTIONS

- Domestic or Export Electric

ACCESSORIES

- Annual Preventative Maintenance Kit
- Daily Time Savings Kit
- Spare Parts Kits: Critical, Motor & Blower, Touch Screen Controls, PTFE Kit



Put the *Most Value* at the
Heart of Your Kitchen
MV74 AUTOMATIC BROILER

As pictured, Broiler with wheeled stand with shelf, and Incendalyst™ Emission Control Device



nieco MV74

Electric

The Broiler Built by Over 50 Years of Experience

DIMENSIONS

	Inches	mm
Width	43.9	1116
Length	42.2	1072
Height	65.8	1671 (with Stand and Incendalyst™)

ENERGY (FACTORY RATED)

Electric Models:

- Domestic or Export Electric: 208-220V, 3Ø, 55A, 50/60Hz
- Export CE Electric: 380V, 3Ø, 32A
- Connected: 20 kW
- Average Consumption: 20kW

WARRANTY

One-year parts and labor. All Nieco equipment is backed by a worldwide sales and service network, with local parts inventories and 24-hour emergency service.

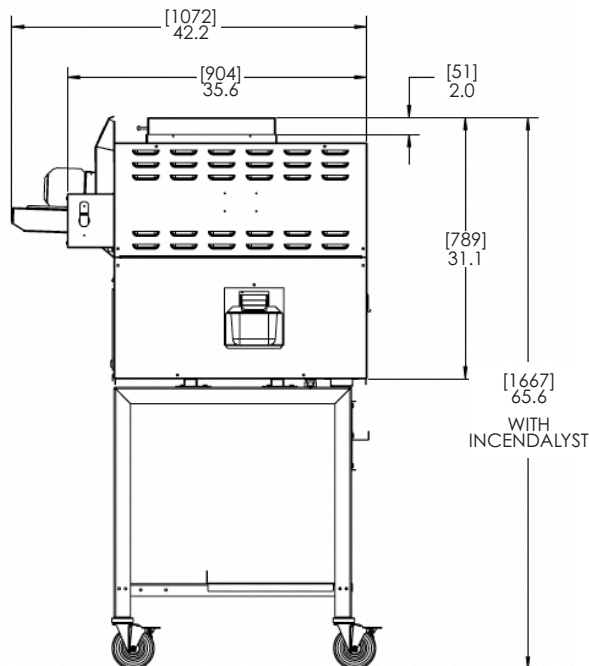
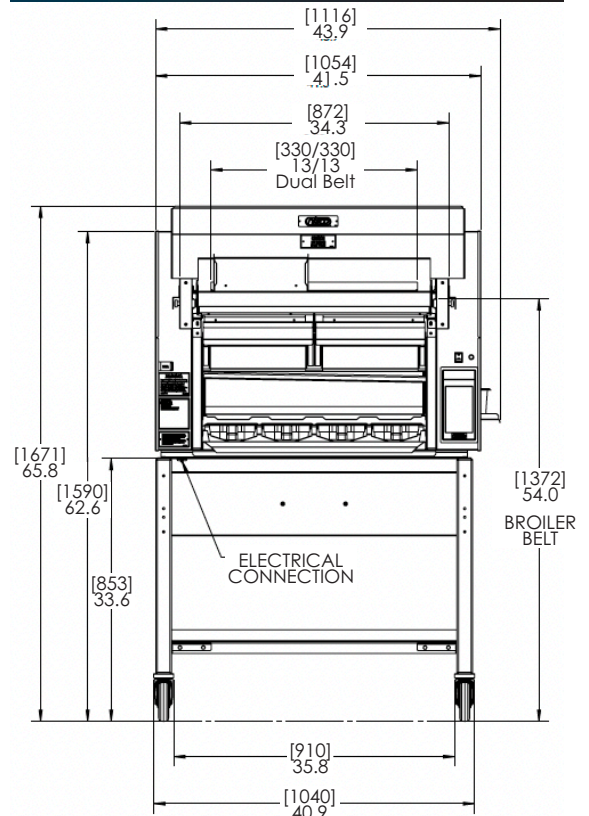

APPROVALS



R005-101763

Call us today at **800-643-2656** or e-mail us at **sales@nieco.com**