

ECO-GAS

Forno a gas modulare per pizzeria, pasticceria e panetteria

Gas oven for pizza, pastry and bread



ECOGAS - EGC I/R

CARATTERISTICHE TECNICHE

- 1 - 2 camere di cottura in acciaio alluminato con piano refrattario ad alte prestazioni
- Bruciatori atmosferici posti sotto il piano refrattario
- Alimentazione a gas con valvole di sicurezza
- Pannello di controllo elettromeccanico (opzione digitale su richiesta)
- Isolamento termico
- Massima temperatura di cottura 450 °C
- Sportello con finestra in vetro temperato
- Sportelli frontali controbilanciati
- Lampade alogene ad alta resistenza e capacità luminosa
- Modulo cappa integrato
- Disponibile in acciaio inossidabile o in stile rustico

ACCESSORI

- Cella di lievitazione ermetica
- Supporto del forno

OPTIONAL

- Pannello di controllo digitale
- Piedi per celle di lievitazione (h min = 8 cm / max = 20 cm)
- 4 ruote (h = 16 cm + 2 cm per la cella di lievitazione)

TECHNICAL SPECIFICATIONS

- 1 - 2 cooking chambers in aluminium coated steel with high performance refractory floor
- Atmospheric burners placed under the refractory floor
- Gas supply with safety valves
- Electromechanical control panel (digital optional by request)
- Thermal insulation
- Max cook temp 450°C
- Single tempered glazed door
- Counter balanced door
- High resistance and efficiency halogen lamps
- Integrated hood module
- Available in stainless steel or rustic style

ACCESSORIES

- Hermetic prover
- Oven support

OPTIONALS

- Digital control panel
- Feet for provers (h min = 8 cm / max = 20 cm)
- 4 wheels (h = 16 cm + 2 cm for the prover)

1 CAMERA + SUPPORTO ALTO
1 DECK + HIGH STAND

ALLACCIO ELETTRICO
ELECTRIC CONNECTION

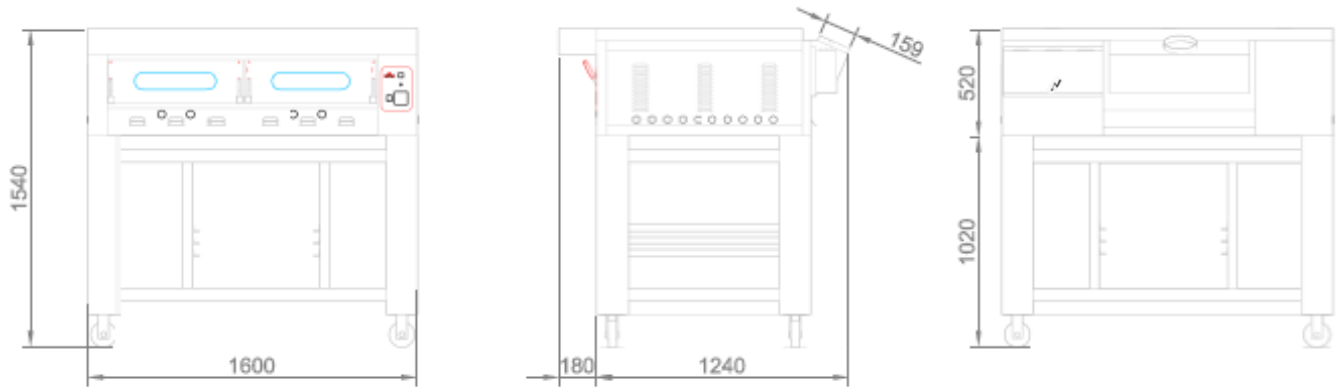

1 CAMERA + CELLA DI LIEVITAZIONE
1 DECK + PROVER

ALLACCIO ELETTRICO
ELECTRIC CONNECTION

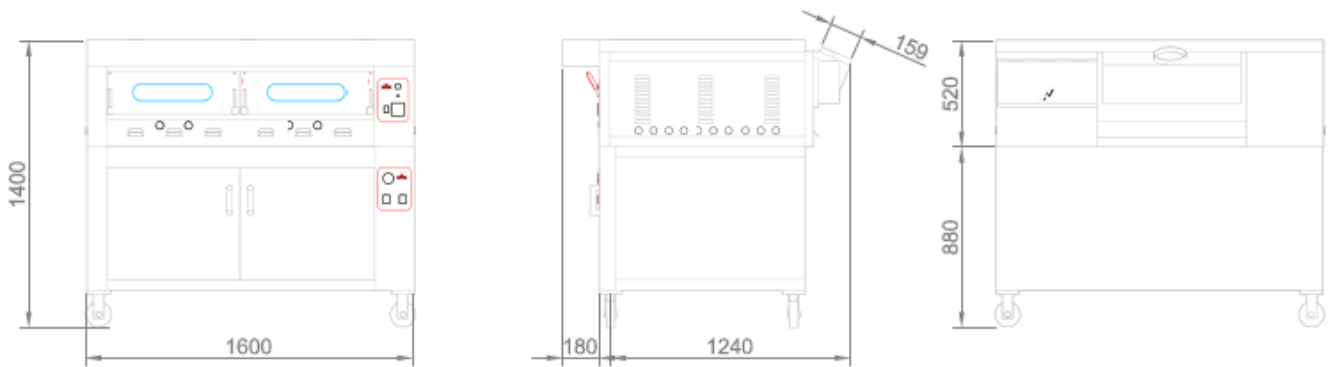

2 CAMERE + SUPPORTO ALTO
2 DECKS + HIGH STAND

ALLACCIO ELETTRICO
ELECTRIC CONNECTION

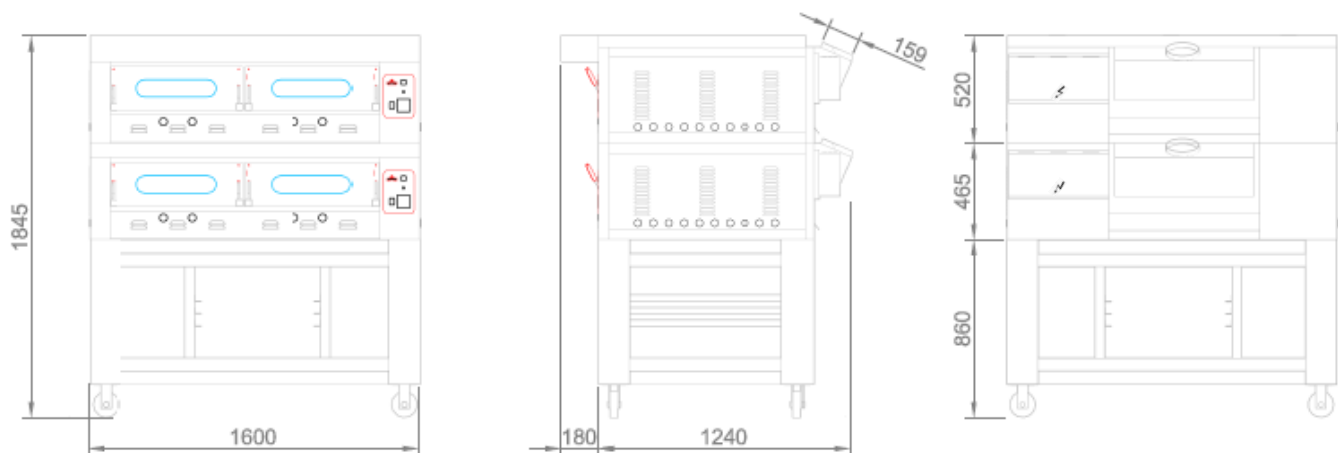

2 CAMERE + CELLA DI LIEVITAZIONE
2 DECKS + PROVER

ALLACCIO ELETTRICO
ELECTRIC CONNECTION

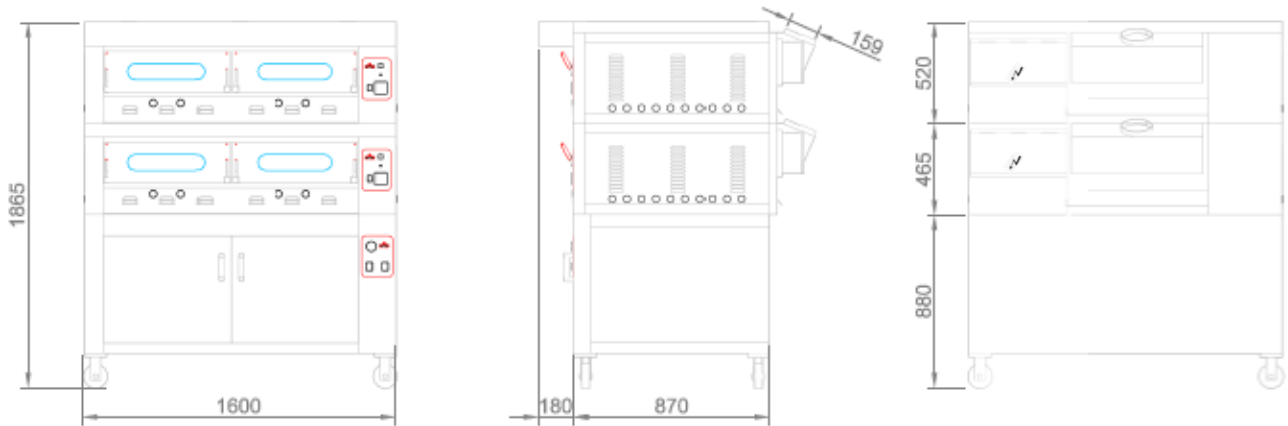

VISTA DALL'ALTO
TOP VIEW

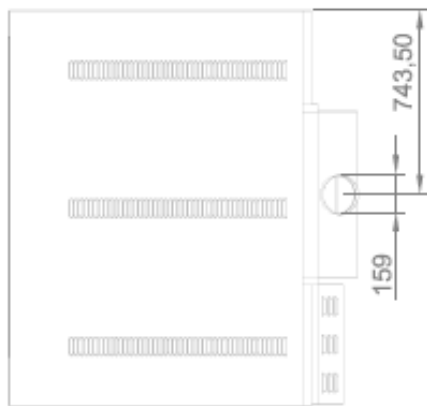

CAPACITÀ DI CARICO PER CAMERA

EGC I/R

DIMENSIONI INTERNE
Internal dimensions
A/H 15 x L/W 123 x P/D 93 cm
12 Pizze Ø 30 cm
4 Teglie 60x40 cm
4 Baking pans 60x40 cm

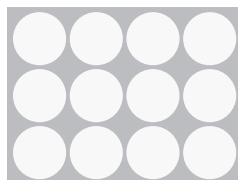

DATI TECNICI
TECHNICAL CHART



EcoGas EGC	Dimensioni interne (cm)			Dimensioni esterne (cm)			Peso	Alimentazione	Potenza	Potenza	Temperatura	N° Teglie
	Internal dimensions (cm)			External dimensions (cm)			Weight	Supply	Power	Power	Temperature	# Baking pans
	A/H	L/W	P/D	A/H	L/W	P/D	KG	V/Ph/Hz	Kcal	Kcal/h	°C	60x40 cm
EGC I/R	15	123	93	47 + 5	160	142	240	230/1/50-60	24000	12500	0/450	4
BGC I/R				70	160	100	100	230/1/50-60			0/90	28
SEGC				86/70/50	160	104	50/46/40					18/12/6
R = Frontale rustico / Country Style Front I = Frontale Acciaio Inox / Stainless Steel Front												