



PETRINS SPIRALE UNIVERSELS - PROGRAMMABLES UNIVERSAL SPIRAL KNEADERS - PROGRAMMABLE

caplain
machines



PE60FE

PEXFE

2 vitesses
Minuterie
Bouchon de cuve
Cuve inox entraînée
Outil spiral inox

9 programmes
Tableau de commande digital
Commandes automatiques ou manuelles

Grille de protection inox relevable
Galets anti-déformation de cuve
Sur roulettes
Patins anti-vibrations
Vérins de mise à niveau

OPTIONS

- Corps de machine en inox
- Marche arrière
- Commandes électromécaniques
- Doseur d'eau
- Couvercle de protection en polyéthylène

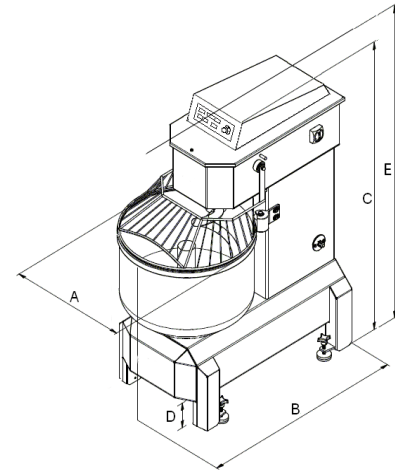

PEXFE

2 speeds
Timer
Bowl tap
Drawn stainless steel bowl
Stainless steel spiral tool

9 programs
Digital control panel
Manual or automatic control

Stainless steel raising safety grid
Anti-strain travelling wheels for bowl
Castors
Anti-vibration pads
Adjustable level

OPTIONS

- Stainless steel body
- Bowl reverser switch
- Electromechanical control panel
- Water measurer
- Protection cover in polyethylene

	PE25FE	PE60FE
Dimensions / Dimensions		
A mm	475	570
B mm	740	1045
C mm	1082	1263
D mm	100	100
E mm (grille ouverte / grid opened)	1350	1600
Poids / Weight		
Kg	188	340
Capacités / Capacities		
Cuve / Bowl (L)	30	75
Coulage / Pouring (L)	9	22
Farine / Flour (kg)	De 1* à 15*	De 1* à 35*
Pâte / Dough (kg)	De 2* à 25*	De 2* à 60*
Nombre de moteurs / Number of motors		
	1	2
Puissance spirale / Power of spiral motor		
1ère vitesse / 1st speed (Kw)	1.1	1.5
2ème vitesse / 2nd speed (Kw)	1.8	2.5
Puissance cuve / Power of bowl motor		
1ère vitesse / 1st speed (Kw)	1.1	0.4
2ème vitesse / 2nd speed (Kw)	1.8	0.7
Voltage / Voltage		
	TRI - 400V - 50/60Hz	

*avec hydratation à plus de 70% et sous réserve du respect de l'utilisation mentionnée / With more than 70% hydration and subject to the respect of the mentioned using