



Autobroil™

Models FR24B(G) FR1212B(G)

Front Return Conveyor Electric & Gas Broilers

Item No: _____

AIA FILE NO. / SPEC NO.

CONSULTANT / CONTRACTOR APPROVAL



Model FR1212B(G)

Marshall Models FR24B(G) & FR1212B(G) Gas and Electric Broilers are designed for high volume hamburger or meat filet production. The 1000° plus metal infrared heat source broils the meat quickly, giving the advantage of speed, plus sealing in juices for better taste.

The Model FR24B(G) has a single 24" belt for broiling while the Model FR1212B(G) has dual 12" broiling belts, which allow for different cooking speeds and menu flexibility. In both models, food is loaded at the front of the broiler and automatically delivered to the front heated holding section.

All Marshall products are supported by a nationwide service organization and in-house, full-time Customer Support Department. To place an order call:

1-800-627-8368

**ETL (US, Canada) & NSF Listed
FOR COMMERCIAL USE ONLY**

**Ask about Marshall's ThermoGlo™ Food Warmers,
companion High Speed Toasters, and Ventilation Systems*

Marshall's large capacity, high production front return hamburger and meat filet broilers. High temperature infrared heat and direct on-conveyor broiling for speed, flavor enhancement and bar marks.

FEATURES

- An integrated control features 6 menu item programs on single belt and 3 per belt on dual belt broilers (time & temperature)
- Control features broiled self-diagnostics
- Optional on-board food probe
- Front return cooking arrangement - Fully automatic
- Electronic ignition – Simply use the on/off switch
- Individual plug-in motors and speed control selectors for each broiler belt
- Convenient functional patty/bun assembly area with ThermoGlo™ technology
- Less removable parts allow fast and easy clean up
- Energy- saving pilot shut-off system (gas)
- Heater holding area with digital control

CONSTRUCTION

- Heavy gauge stainless steel solid weld frame construction
- 3/16" Diameter, heavy duty stainless steel conveyor rods
- Stainless steel internal gas lines (gas models)
- Simple conveyor tension adjustment
- Easy to operate computer control panel
- Heavy-duty industrial grade heating elements or gas burners

VOLUME

Hamburger Peak Production:

Frozen	2 oz. patties	850/hr.
	4 oz. patties	510/hr.
Fresh	2 oz. patties	1,060/hr.
	4 oz. patties	640/hr.

(Figures for estimating only. Actual production varies with fat content, surface texture and meat starting temperature.)

Marshall Air Systems, Inc.

419 Peachtree Drive South • Charlotte, North Carolina 28217 USA • Phone: (704) 525-6230 Fax: (704) 525-6229 • www.marshallair.com



Autobroil™

Models FR24B(G) & FR1212B(G)

Front Return Conveyor Gas & Electric Broilers

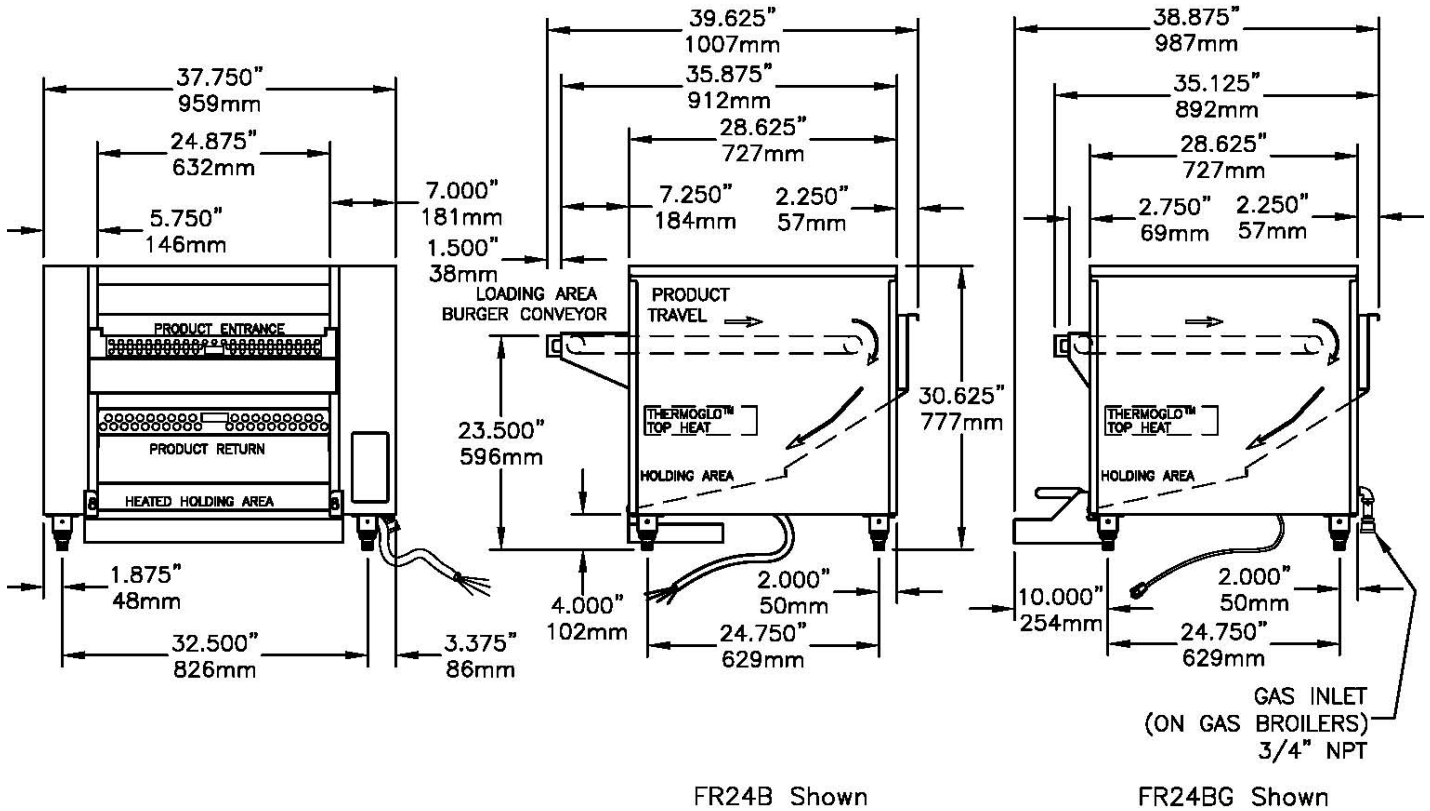

FR24B Shown

FR24BG Shown

Overall Dimensions Models FR24B(G) & FR1212B(G)

Dimensions:	Height: 30.625" 777mm	Width: 37.750" 959mm	Depth – Electric Units: 39.625" 1007mm	Depth – Gas Units: 38.875" 987mm
Shipping Information:	Weight: Net 455 lbs. 207 kilos	Ship Wt: 495 lbs. 225 kilos	Freight (USA) NMFC Class 85	Ship. Cubes: 58.2 cubic ft. 1.65 cubic meters
Electrical:	Electric Units 208V/60Hz/3 ph 54 amps/ 16 kw (L1,L2,L3,G) 220V/50Hz/3 ph 48 amps/ 15 kw (L1,L2,L3,G) 380V/50Hz/3 ph 29 amps/ 16 kw (L1,L2,L3,N,G)		Gas Units 120V/60Hz/1 ph 13 amps/ 1.56 kw 240V/50Hz/1 ph 7 amps/ 1.68 kw	
Gas Supply:	N/A		97,000 BTUH – LP or Nat. 3/4" NPT Supply	
Options:	Autocat™ - Catalytic Converter Complete spare parts supply kit International voltages Heavy-duty stainless steel stand with casters 48" Flexible gas line with quick disconnect and restraining device (<i>gas units</i>) Food probe		Autoloader™ - Automatic Loading System Extended Loading Arms Companion Ventilation System	

Marshall Air Systems, Inc.

419 Peachtree Drive South • Charlotte, North Carolina 28217 USA • Phone: (704) 525-6230 Fax: (704) 525-6229 • www.marshallair.com