

# TECHNICAL FILE **FastTop**

**45** fruits/min.

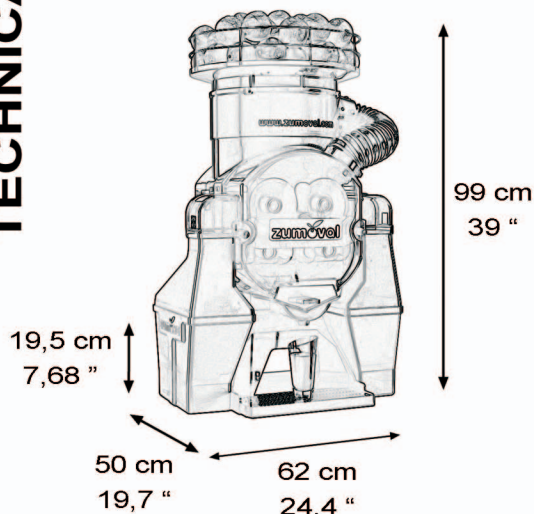

## SPECIFICATIONS:

<b>Motorforce group:</b>	<b>Motor reducer 0,75 CV.</b>	
<b>Voltage (monophasic):</b>	<b>230V. - 50/60 Hz.</b>	<b>110/125V. - 60 Hz.</b>
<b>Consumption:</b>	<b>4,1 / 3,7 A.</b>	<b>9 / 8,6 A.</b>
<b>Electrical protection:</b>	<b>Overloading and temperature.</b>	
<b>Security:</b>	<b>Automatic inductive proximity sensor.</b>	
<b>Fruit Diameter:</b>	<b>60 - 80 mm (2,36 " - 3,15 ").</b>	
<b>Capacity of peel bucket:</b>	<b>20 Kg (44 lbs).</b>	
<b>Capacity of feeder:</b>	<b>18 Kg (39 lbs).</b>	
<b>Weight:</b>	<b>47,5 Kg (104,7 lbs).</b>	

## OPTIONS:



Orange / silver  
colour



Orange  
counter



Self service  
tap



Automatic  
shower

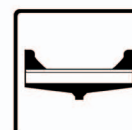

Big capacity  
juice tray



Available on all models  
with "us" suffix