

MTF
MCF
MCV
F / SERIE



(MTF) MESA DE TRANSPORTE

CONVEYING TABLE / MESA DE TRANSPORTE / TABLE DE TRANSPORT

(MCF) MESA DE CORTE

CUTTING TABLE / MESA DE CORTE / TABLE DE DÉCOUPE

(MCV) MESA DE CORTE VERTICAL

VERTICAL CUTTING TABLE / MESA DE CORTE VERTICAL / TABLE DE DÉCOUPE VERTICAL

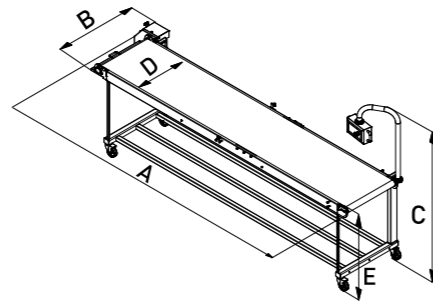

CC_014-11		MTF620	MTF630	MTF640	MTF650	MTF660	MTF830	MTF840	MTF850	MTF860	MTF130	MTF140	MTF150	MTF160
POTÊNCIA (kW)-(hp) Power / Potencia / Puissance	230V.1ph. 50-60Hz	0,37 (0,5)	0,37 (0,5)	0,37 (0,5)	0,37 (0,5)	0,37 (0,5)	0,37 (0,5)	0,37 (0,5)	0,37 (0,5)	0,37 (0,5)	0,37 (0,5)	0,37 (0,5)	0,37 (0,5)	0,37 (0,5)
PESO LÍQUIDO (kg)-(lb) Net weight / Peso neto / Poids net		170 (374,78)	200 (440,92)	240 (529,10)	270 (595,24)	300 (661,38)	200 (440,92)	250 (551,15)	285 (628,31)	315 (694,45)	220 (485,01)	275 (606,27)	320 (705,47)	355 (782,63)
DIMENSÕES (mm)-(in) Dimensions / Dimensiones / Dimensions	A	2330 (91 3/4)	3330 (131 1/8)	4330 (170 1/2)	5330 (209 13/16)	6330 (249 3/16)	3330 (131 1/8)	4330 (170 1/2)	5330 (209 13/16)	6330 (249 3/16)	3330 (131 1/8)	4330 (170 1/2)	5330 (209 13/16)	6330 (249 3/16)
	B	900 (35 7/16)	900 (35 7/16)	900 (35 7/16)	900 (35 7/16)	900 (35 7/16)	1100 (43 5/16)	1100 (43 5/16)	1100 (43 5/16)	1100 (43 5/16)	1300 (51 3/16)	1300 (51 3/16)	1300 (51 3/16)	1300 (51 3/16)
	C	1650 (64 15/16)	1650 (64 15/16)	1650 (64 15/16)	1650 (64 15/16)	1650 (64 15/16)	1650 (64 15/16)	1650 (64 15/16)	1650 (64 15/16)	1650 (64 15/16)	1650 (64 15/16)	1650 (64 15/16)	1650 (64 15/16)	1650 (64 15/16)
	D	630 (24 13/16)	630 (24 13/16)	630 (24 13/16)	630 (24 13/16)	630 (24 13/16)	830 (32 11/16)	830 (32 11/16)	830 (32 11/16)	830 (32 11/16)	830 (32 11/16)	1030 (40 9/16)	1030 (40 9/16)	1030 (40 9/16)
	E	910 (35 13/16)	910 (35 13/16)	910 (35 13/16)	910 (35 13/16)	910 (35 13/16)	910 (35 13/16)	910 (35 13/16)	910 (35 13/16)	910 (35 13/16)	910 (35 13/16)	910 (35 13/16)	910 (35 13/16)	910 (35 13/16)

ESTAÇÕES / STATIONS / ESTACIONES / STATIONS

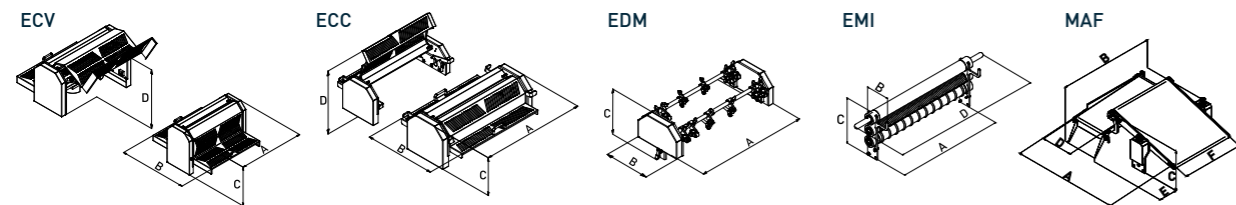

CC_014-11		MCF620	MCF630	MCF640	MCF650	MCF660	MCV630	MCV640	MCV650	MCV660
POTÊNCIA (kW)-(hp) Power / Potencia / Puissance	230V.1ph.50-60Hz	0,37 (0,5)	0,37 (0,5)	0,37 (0,5)	0,37 (0,5)	0,37 (0,5)	0,37 (0,5)	0,37 (0,5)	0,37 (0,5)	0,37 (0,5)
PESO LÍQUIDO (kg)-(lb) Net weight / Peso neto / Poids net		170 (374,78)	200 (440,92)	240 (529,10)	270 (595,24)	300 (661,38)	223 (491,63)	264 (582,01)	305 (672,40)	346 (762,79)
DIMENSÕES (mm)-(in) Dimensions / Dimensiones / Dimensions	A	2330 (91 3/4)	3330 (131 1/8)	4330 (170 1/2)	5330 (209 13/16)	6330 (249 3/16)	3330 (131 1/8)	4330 (170 1/2)	5330 (209 13/16)	6330 (249 3/16)
	B	900 (35 7/16)	900 (35 7/16)	900 (35 7/16)	900 (35 7/16)	900 (35 7/16)	900 (35 7/16)	900 (35 7/16)	900 (35 7/16)	900 (35 7/16)
	C	1650 (64 15/16)	1650 (64 15/16)	1650 (64 15/16)	1650 (64 15/16)	1650 (64 15/16)	1650 (64 15/16)	1650 (64 15/16)	1650 (64 15/16)	1650 (64 15/16)
	D	630 (24 13/16)	630 (24 13/16)	630 (24 13/16)	630 (24 13/16)	630 (24 13/16)	630 (24 13/16)	630 (24 13/16)	630 (24 13/16)	630 (24 13/16)
	E	910 (35 13/16)	910 (35 13/16)	910 (35 13/16)	910 (35 13/16)	910 (35 13/16)	910 (35 13/16)	910 (35 13/16)	910 (35 13/16)	910 (35 13/16)
	F	-	-	1366 (53 3/4)	1942 (76 7/16)	2380 (93 11/16)	-	1237 (48 11/16)	1813 (71 3/8)	2251 (88 5/8)
	F'	-	-	510 (20 1/16)	1087 (42 13/16)	1525 (60 1/16)	-	382 (15 1/16)	958 (37 11/16)	1396 (54 15/16)
	G	559 (22)	1559 (61 3/8)	2559 (100 3/4)	3433 (135 3/16)	4433 (174 1/2)	-	2559 (100 3/4)	3433 (135 3/16)	4433 (174 1/2)
	G'	-	-	697 (27 7/16)	995 (39 3/16)	1557 (61 5/16)	870 (34 1/4)	568 (22 3/8)	866 (34 1/8)	1428 (56 1/4)
	H	870 (34 1/4)	870 (34 1/4)	870 (34 1/4)	870 (34 1/4)	870 (34 1/4)	1320 (51 15/16)	870 (34 1/4)	870 (34 1/4)	870 (34 1/4)

CC_014-11		EVC600	ECC600	EDM600	EMI600	MAM600
MESAS Tables / Mesas / Tables		MCV	MCF, MCV	MCF, MCV	MCF, MCV	MCF, MCV
FILAS Rows / Filas / Files		-	1 - min 310 [12 3/16] max 400 [15 3/4] 2 - min 255 [10 1/16] max 300 [11 13/16]	-	-	-
PRESSÃO MÁX. AR (bar) Max. air pression / Presión max. aire / Pression d'air max.		7-10	-	-	-	-
CONSUMO MÉDIO AR (l/min) Average consumption air / Consumo medio aire / Consummation d'air moyenne		240	-	-	-	-
** COMPRESSOR - CAPACIDADE DEPÓSITO AR (l) ** Air pump - Tanks capacity air / Compresor - Capacidad del depósito aire / Compresseur - Capacité du réservoir air		300-400	-	-	-	-
POTÊNCIA (kW)-(hp) Power / Potencia / Puissance	230-400V.3ph.50-60Hz	-	-	-	-	0,18 [0,2]
PESO LÍQUIDO (kg)-(lb) Net weight / Peso neto / Poids net		42,5 [93,7]	14 [30,86]	12 [26,46]	15 [33,07]	46 [101,41]
DIMENSÕES (mm)-(in) Dimensions / Dimensiones / Dimensions	A	730 [28 3/4]	730 [28 3/4]	730 [28 3/4]	630 [24 13/16]	890 [35 1/16]
	B	753 [29 5/8]	496 [19 1/2]	300 [11 13/16]	138 [5 7/16]	960 [37 13/16]
	C	443 [17 7/16]	277 [10 7/8]	267 [10 1/2]	270 [10 5/8]	500 [19 11/16]
	D	640 [25 3/16]	520 [20 1/2]	625 [24 5/8]	879 [34 5/8]	300 [11 13/16]
	E	-	-	-	-	275 [10 13/16]
	F	-	-	-	-	600 [24 5/8]

** Compressor (não fornecido) isento de óleo ou lubrificado com óleo alimentar / Air pump (not supplied), no need of oil or lubricated with edible oil / Compresor (N/D) sin necesidad de aceite o lubricado con aceite alimentario / Compresor (Non Fourni) n'a pas besoin d'huile ou de lubrification avec de l'huile alimentaire / Ölfreier Kompressor (wird nicht mit der Maschine geliefert); Outras tensões de alimentação: sob consulta / Further power supplies: by request / Otras tensiones eléctricas: bajo consulta / Autre tension d'alimentation: sur demande.