



Catalogue :

SERIE 900 KORE

Chapter :

BOILING PANS 900 KORE

Article :

M-G915 LPG 230V 1N 50Hz

Code:

19020556

<u>DIMENSIONS AND WEIGHTS</u>		<u>Net dimensions</u>	<u>Packed</u>
Length	mm	800,00	1.080,00
Depth	mm	930,00	840,00
Height	mm	850,00	1.265,00
Weight	kg	120,00	150,00
Volume	m3	0,69	1,15
<u>ELECTRICITY</u>		50Hz	
	Power		0,10 kW
Connections	230 V. 1+N+T	NO	
	230 V. III+T	3X10+T - 63 A	
	400 V. III+N+T	4X25+T -125 A	
<u>GAS</u>			
	Power		24,00 kW
	Gas type	LPG	
	Consumption		1,84 kg/h
	Pressure	LPG G30/G31 28-30/37 mbar	
<u>WATER</u>			
	Pressure	Water Pres:200-400kPa(2-4bar)	
<u>STEAM</u>		Not necessary	
<u>AIR</u>		Not necessary	
<u>SOUND LEVEL</u>			< 65,00 db
<u>CERTIFICATES</u>		1312CS6211	
<u>INSTALLATION - CONNECTIONS</u>			<u>Ø</u>
	▶ ELECTRICITY	SI	
	▶ COLD WATER		"1/2""
	▶ HOT WATER		"1/2""
	▶ GAS		"R,3/4""G"

DESCRIPTION

GAS BOILING PAN DIRECT HEAT, M-G915

Boiling pans are ideal to cook, simmer or stew different types of food in large quantities and volume.

2 mm stainless AISI-304 steel top with rounded edges for easy cleaning. Laser cut and automatic welding for a perfect adjustment of sides between modules with square angle finish.

The pan is integrated in the top by robotic welding. It is made of AISI-304 stainless steel and the bottom is made of stainless steel AISI-316L. Side walls with satin polished, for easy cleaning.

150 litre capacity model.

Direct gas heating by means of stainless steel pipe burners with optimized combustion and sequential ignition controlled by energy regulator.

The heat from the burners at the bottom of the pan spreads evenly both throughout the base and the side walls for a gradual heating of the pan.

The regulator allows different power levels to control the burners operation.

Electronic ignition of the burners group. Access tube for manual ignition.

The pan can be filled with cold or warm water by means of electro valves activated by a single switch at the front panel.

2" pan discharge safety tap with thermal insulator handle easy to operate without any effort.

Easy to remove, robust and reliable AISI-304 stainless steel discharge filter.

Double side lid, balance by hinge and front handle for diagonal opening at 75° that allows the lid to remain open at any position.

Perfect adjustment of the lid to reduce cooking time and save energy.

Led indicator for connected and working equipment.

Water-tight and protecting-support controls.

High temperature protector for the chimney made of enamelled cast iron.

Front access to components.

According to European standards for components and panels temperature, efficiencies and combustion, and sanitary regulations (EN-60335 and EN-203)

IPX5 grade water protection equipment.

Maximum power: 24.0 kW - Gas

It requires an 230V - 1+N power supply.

Dimensions: 800 x 930 x 850 mm.



Catalogue :
SERIE 900 KORE

Chapter :
BOILING PANS 900 KORE

Article :
M-G915 LPG 230V 1N 50Hz

Code :
19020556

SCHEMA - DIMENSIONS

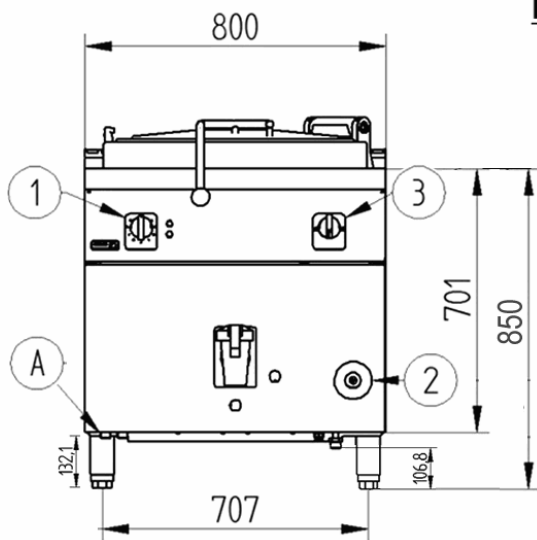

M-G910

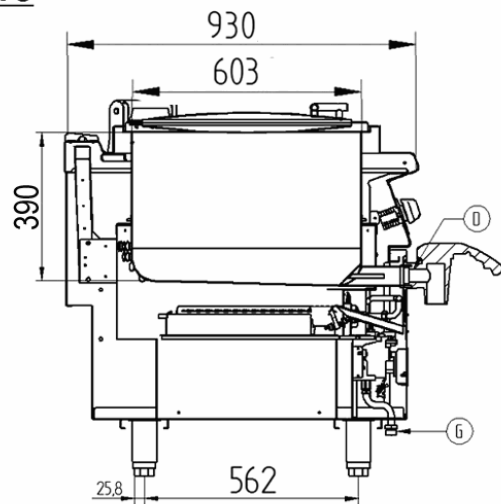

M-G915

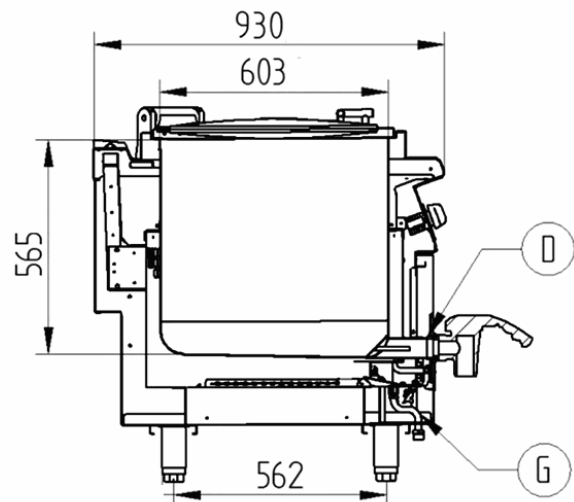

- A – Entrada de Agua
- G – Entrada de Gas
- D – Desagüe
- 1 – Grifo válvula de gas
- 2 – Pulsador tren de chispas
- 3 – Grifo de entrada de agua

- Water Inlet
- Gas Inlet
- Drainage
- Gas valve tap
- Piezoelectric ignitor
- Water inlet tap