



Catalogue
LAUNDRY
Chapter
IRONING AND FOLDING

Model
 PE-18/100 M 230V 1N 50/60Hz

19017134

WALL IRONER, PE-18/100 M

- Wall mounted and small in size, they can be positioned in very limited spaces and require hardly any installation since they do not have any kind of exhaust or connection, except to the electric current.
- Unit exterior in stainless and lacquered steel.
- Anodised aluminium bucket.
- Front loading and unloading.
- Safety protector for hands.
- Electronic microprocessor for temperature regulation.
- Safety thermostat.
- Electric heating system.
- Movement of the tray manual, by pedal.
- Anodised aluminium tray Roller manufactured in polyester.
- Tray roller NOMEX in option.

"Note: You are recommended to insert the linen with a moisture level of between 20 and 25%."

DIMENSIONS

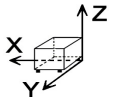

X Width	1286 mm	X Gross width	1450 mm
Y Depth	430 mm	Y Gross depth	450 mm
Z Height	970 mm	Z Gross height	1140 mm
Net Weight	90,8 kg	Gross Weight	104,0 kg
Net volume	0,540 m3	Gross volume	0,744 m3

ELECTRICITY TECHNICAL SPECIFICATIONS

Engine power	0,03 kW
Electric power	3,329 kW
Heating power	3,30 kW
Voltage	230V - 1N
Electric frequency	50/60Hz

CONNECTIONS TECHNICAL SPECIFICATIONS

230 V three-phase wiring	3X1,5+T-16A
Single-phase 230V wiring	2X2,5+T-25A
Three-phase +N 400V wiring	4X1,5+T-10A

OTHERS

Roller length in cm	100,00 cm
Roller diameter	180 mm
Production 20-25 % moisture	15 kg/h
Operational speed	2,02 m/min
Noise level	45,00 dB



Catalogue
LAUNDRY

Chapter
IRONING AND FOLDING

Model
PE-18/100 M 230V 1N 50/60Hz

19017134

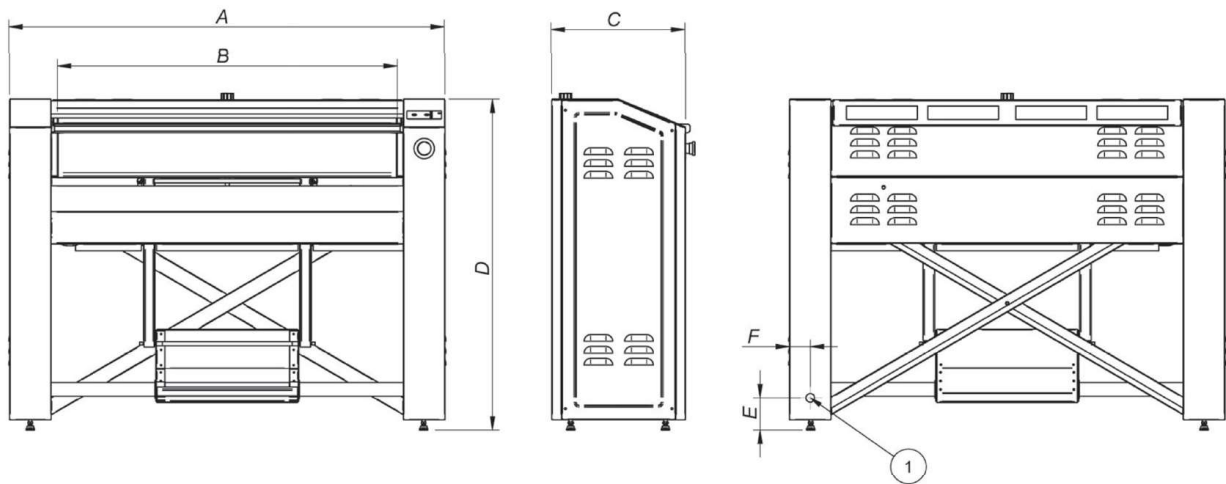

Model	A	B	C	D	E	F
PE-18/100	1.286	1.000	400	970	95	61
PE-18/120	1.486	1.200	400	970	95	61