

# EQVI016 or EQVI016/500W 1000W or 500W WARMER

## EXPLODED VIEW

- 11-01 HOOD
- 11-02 HOOD STIFFENER
- 11-03 VERTICAL STRUT
- 11-04 FIXING BRACKET
- 11-05 LIGHT REFLECTOR
- 11-06 WIRE GUARD
- 11-07 HOOD DTIFFENER BLANK
- 11-08 SPACER BRACKET
- 11-09 FRONT FOOT TUBE
- 11-10 SIDE TUBE
- 11-11 WIDTH TUBE
- 11-12 HEAT LAMP BRACKET

- MF PT400200, PLASTIC BUNG 40mm x 20mm
- MF PS300-1530JB, PLASTIC BUNG 30mm x 30mm
- MF HH211, 1000W LAMP
- OR
- BA HH210500W, 500 LAMP

- MF PLATE, SERIAL PLATE
- VI SW17, RED ROCKER SWITCH
- VI LE14, SWITCH MEMBRANE
- GS GAST42004, GASTRONOME PAN

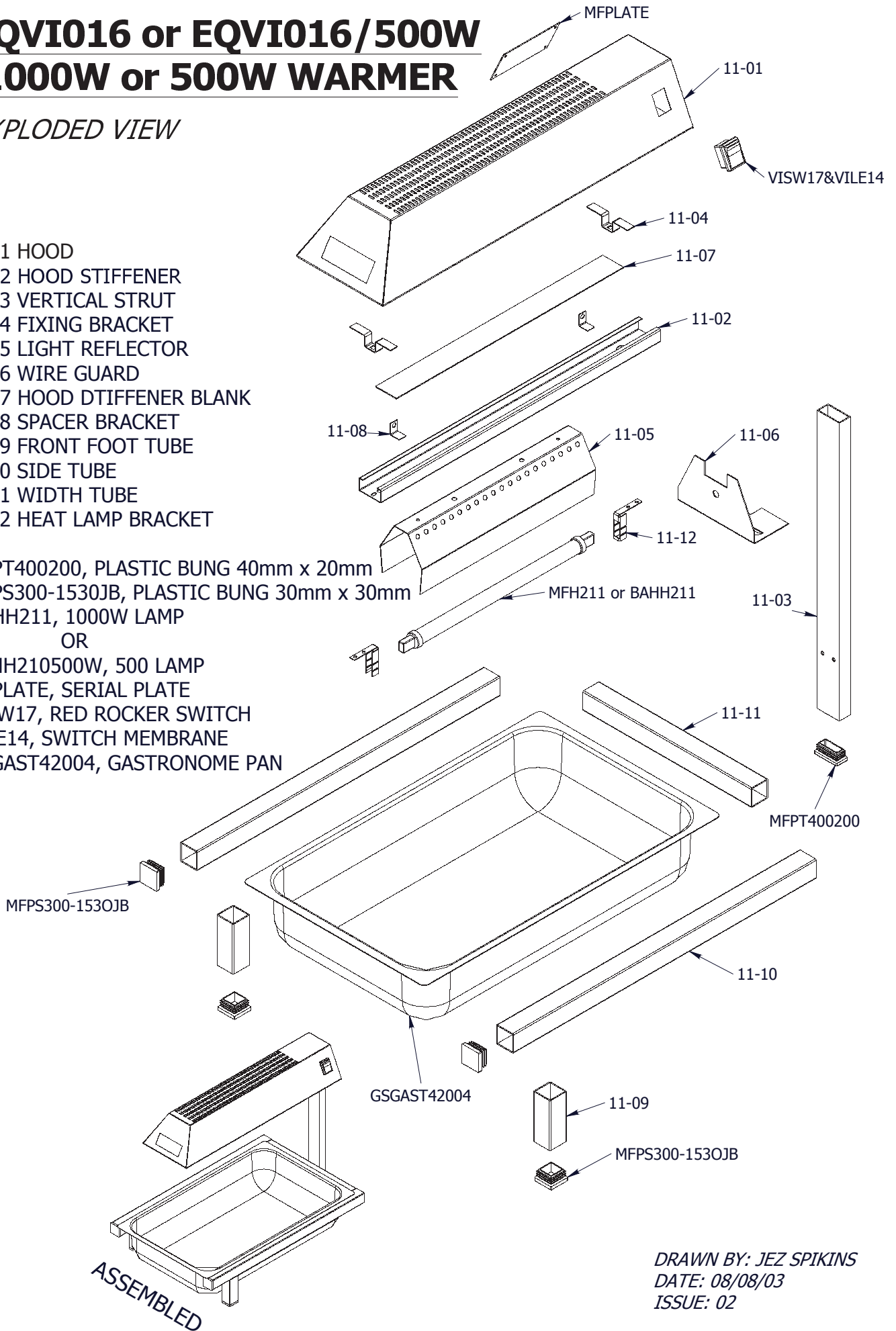

DRAWN BY: JEZ SPIKINS  
DATE: 08/08/03  
ISSUE: 02